

ELM-16-5.4-8-S



Lens module specifications

Effective focal length	16.0	mm	
F/#	5.4	(Fixed)	
Maximum sensor format	1/2.3	inch	
Maximum image circle (Φ)	8	mm	
Lifecycles (10-90% sinusoidal)	>1'000'000'000	cycles	
FOV	Diagonal	28	°
	Horizontal	22	°
	Vertical	16.6	°
Mechanical Back Focal Length	4.62	mm	
Optical Distortion	< -3.5	%	
Pixel size recommended	1.8	μm	
Wavelength range	486-656	nm	
Relative illumination	> 75	%	
Max chief ray angle	7.0	°	
Working distance range	270 - infinity	mm	
Mount	M12x0.5		S-mount
Connector type	FPC		2 pins
Total Track Length	25.62	mm	Liquid Lens included
Dimension (Φ x L)	14 x 21.8	mm	

Focus tunable lens specifications

EL-3-10-VIS-26D

Focal power range (@20°C) ³	-13 to +13	dpt	
Wavefront error @525nm (vertical/horizontal)	<0.2/<0.2	λRMS	
Operating temperature	-20 to +65	°C	
Storage temperature	-50 to +85	°C	
Temperature compensation	No		

Electrical specifications

Control current (typical)	-120 to +120	mA	
Operating voltage	-1...1	V	
Power consumption (full tuning range)	0 to 100	mW	$P = R_{coil} \times i^2$
Power consumption (+/- 5 dpt tuning range)	0 to 15	mW	
Settling time	2 to 4	ms	Low pass filtered / normal step signal

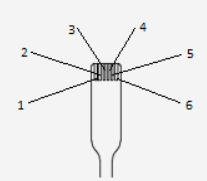
FPC connector	Function	Sensor pins	
Pin 1	-	-	
Pin 2	Control current -	-	
Pin 3	Control current +	-	
Pin 4	-	-	
Pin 5	-	-	
Pin 6	-	-	

Controller

The ELM-16-5.4-8-S can be controlled by Optotune's Lens Driver 4 driver by simply connecting the flex cable of the lens to the Molex connector on the lens controller. It's important to note that +/-120 mA is required to tune across the whole optical power range. As the lens controller can output more current, it has to be connected to the PC without the lens connected first. Then, in the "Hardware Configurations" tab of the Lens Driver Controller Software, the software limit has to be set to +/-120 mA. Now the lens can be connected. The current will now only be adjustable from +/-120 mA, hence an overdriving of the lens can be prevented.



For high-volume applications integrated current controller ICs with I2C control can be recommended:

- Rohm BU64295GWZ, BU64296GWX or BU64297GWZ (100mA bipolar – different package sizes).
- Texas Instruments DRV201 (100mA unipolar)
- OnSemiconductor LV8498CT (150mA unipolar)

Additional selection of controllers is available at <https://www.optotune.com/controllers>

Mechanical drawings

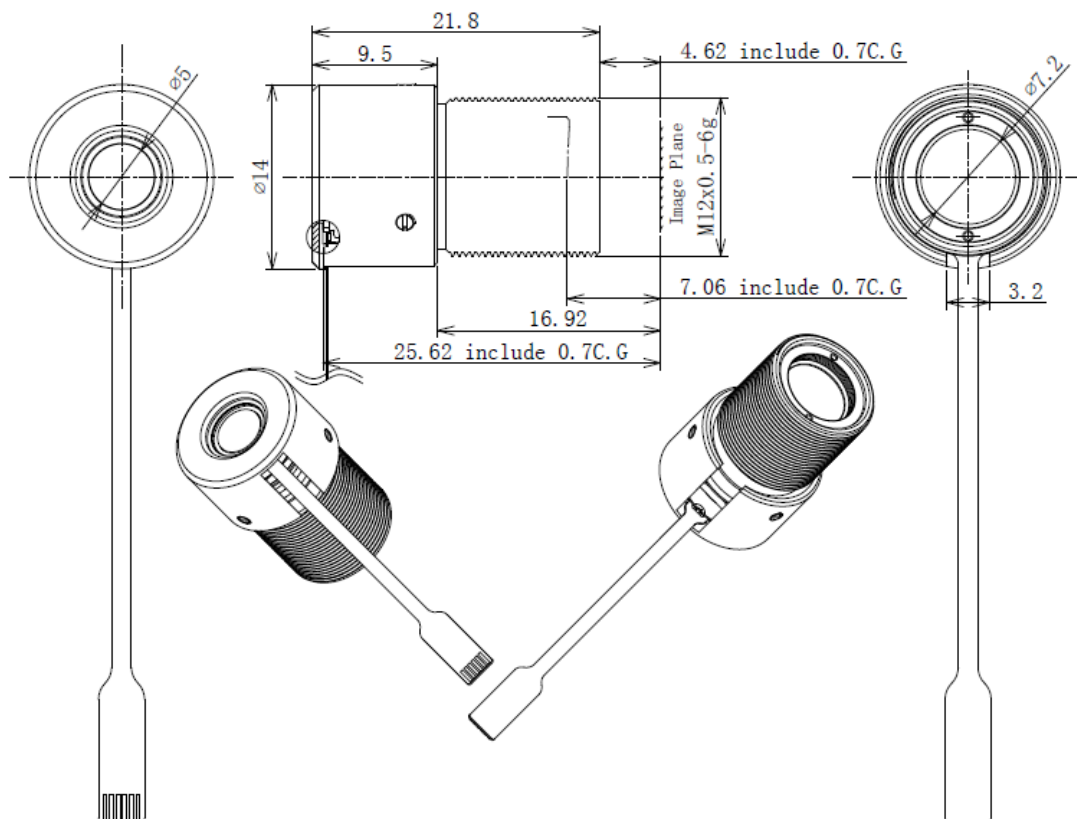

Figure 1: Mechanical drawing of the ELM-16-5.4-8-S

For more information on optical, mechanical and electrical parameters, please contact sales@optotune.com.