



Electrically tunable lens EL-16-40 (5D version)

The EL-16-40 is a focus tunable lens based on Optotune's proprietary shape changing polymer lens technology. By applying an electric current, the lens curvature is adjusted within milliseconds from concave to convex, providing a focal power range of -2 dpt to +3 dpt. With actuators based on proven voice-coil technology, the EL-16-40 is extremely reliable and robust, well suited even for applications in harsh environments over large temperature ranges. To achieve good repeatability and focus stability, an integrated temperature sensor allows for in-situ compensation of temperature effects. Since 2024 the EL-16-40 is also available with technology to compensate for gravity effects, resulting in **consistent wavefront quality irrespective of lens orientation**.

The EL-16-40 is available in its compact form for OEM integration but also with multiple thread adapters and a robust Hirose connector for industrial use.

Typical applications for this large aperture lens include machine vision, microscopy and ophthalmic devices.

Lens specifications

Clear aperture	16	mm
Focal power range (30°C, ±250 mA)	-2 to +3	dpt
Focal power @ 0 mA (25°C, typical)	0.5 +/-1.0	dpt
Repeatability in focal power mode	0.02 (std dev, class 1) 0.06 (std dev, class 2)	dpt
Transmission range	VIS: 420 to 950 NIR: 850 to 1500	nm
Wavefront error @ 0 dpt (Optical axis vertical / horizontal)	<0.15 / <0.5 (class 1) <0.25 / <0.5 (class 2) <0.15 / <0.16 (class 1, GTC version) <0.25 / <0.26 (class 2, GTC version)	λ RMS @ 532 nm
Optical axis accuracy	1.0	mrad (typical)
Optical axis repeatability	0.01	mrad (STD, typical)
Lens type	plano-concave to plano-convex	
Refractive index / Abbe number	$n_D = 1.30 / v = 100$	
Response time (typ. at 30°C, 0 to ±250 mA step)	5	ms
Settling time (typ. at 30°C, 0 to ±250 mA step)	12.5 (with signal conditioning) 25 (rectangular step)	ms
Lifecycles (10% - 90% sinusoidal)	> 1'000'000'000	
Operating temperature	-20 to 65	°C
Storage temperature	-40 to 85	°C
Weight of OEM / C-mount lens	40 / 80	g

Electrical specifications

Nominal control current	-250 to 250	mA
Absolute max. control current	-500 to 500	mA
Motor coil resistance @ 25°C	12	Ω
Power consumption (nominal 0 - 250 mA)	0 - 0.7	W
Max power consumption (@ 500 mA)	3.0	W
Temperature sensor incl. EEPROM	STTS2004 (STMicroelectronics)	
Absolute maximum voltage (coil)	10	V
Absolute maximum voltage (memory & sensor)	4.3	V

Overview of available standard products

Standard Product ^{1,2,3,4}	Tuning range	Top thread	Bottom thread
EL-16-40-TC-VIS-5D	-2 to +3 dpt	None	None
EL-16-40-TC-VIS-5D-M25.5	-2 to +3 dpt	M25.5x0.5 male	M40.5x0.5 female
EL-16-40-TC-VIS-5D-M26	-2 to +3 dpt	M26x0.706 male	M26x0.706 female
EL-16-40-TC-VIS-5D-M27	-2 to +3 dpt	M27x0.5 male	M40.5x0.5 female
EL-16-40-TC-VIS-5D-M30.5	-2 to +3 dpt	M30.5x0.5 male	M40.5x0.5 female
EL-16-40-TC-VIS-5D-C	-2 to +3 dpt	C-mount male	C-mount female
EL-16-40-TC-VIS-5D-M42	-2 to +3 dpt	M42x1 male	M42x1 female

- 1 All models are available with gravity compensation technology (GTC models)
- 2 All models are available with NIR coating or custom coating upon request
- 3 All models are available as class 1 with wavefront error <math>< 0.15 \lambda \text{ RMS}</math> and repeatability <math>< 0.02 \text{ dpt}</math>
- 4 The models with thread adapters are all available with built-in lens controller ECC-1C

Liquid lens working principle

The working principle of the EL-16-40 is based on Optotune's well-established technology of shape-changing polymer lenses. The core that forms the lens contains an optical fluid, which is sealed off with an elastic polymer membrane as shown in Figure 1. An electromagnetic actuator (VCM) is used to exert pressure on the container and therefore changes the curvature of the lens. By changing the electrical current flowing through the coil of the actuator, the optical power of the lens is controlled.

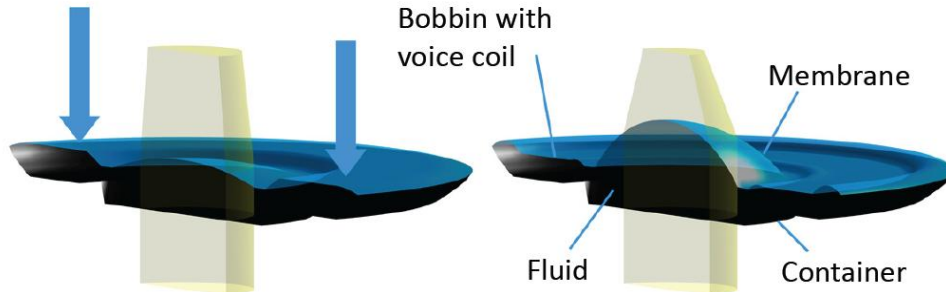

Figure 1: Working principle of the sealed lens container filled with an optical fluid and embedded in an EL-16-40 housing.

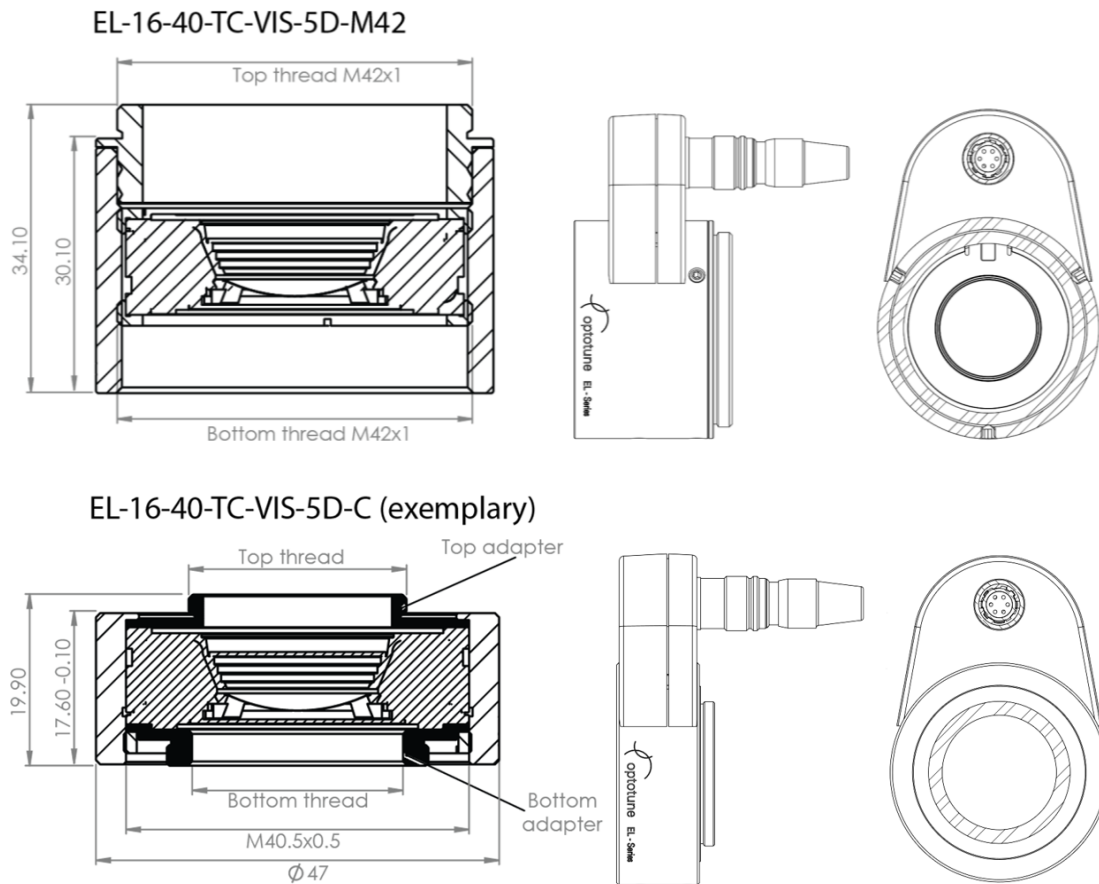
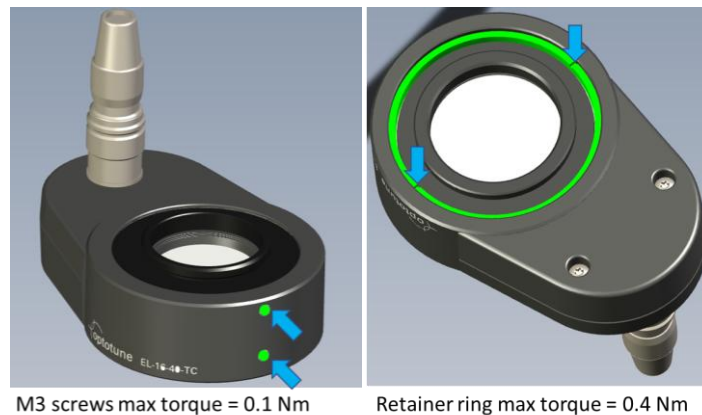

Figure 3: Mechanical drawing of EL-16-40-TC-VIS-5D-M42 and EL-16-40-TC-VIS-5D-C, whereas the latter example also represents the combinations –M25.5, –M26, –M27, –M30.5 (unit: mm).

Attention: The distance from flange to bottom cover glass of the EL-16-40-TC-VIS-5D-C is 4.8mm. Please make sure not to screw in any C-mount lenses with protruding optics as they may scratch or even crack the glass.

The design features two M3 screws on the side, which are used to lock the position of the thread adapters. The upper M3 screw can be loosened to freely rotate the Hirose connector against the top thread if needed. The lower M3 screw holds in place the bottom thread. Each M3 screw can be tightened with a maximum torque of 0.1 Nm. It is recommended to first loosen both M3 screws, tighten the retainer ring, then tighten the M3 screws.



Attention: Exceeding the above max torque specifications may introduce hysteresis or damage the lens.

Electrical connection

The electrical connection of the EL-16-40 without adapters consists of a FPC flex cable with 6 pins suitable for Molex 503480-0600, Amphenol SFV12R-2STE1HLF or equivalent connector. Two pins are for the coil of the lens, the other four pins are for the I²C connection to the temperature sensor and EEPROM. The I2C addresses are 0x18 and 0x50, respectively.

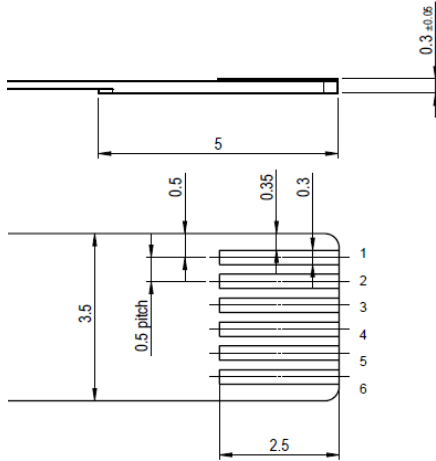

Pin out: EL-16-40-TC		
Position	Function	Value
1	GND	-
2	Max. control current -	-500 to 500 mA
3	Max. control current +	-500 to 500 mA
4	I ² C SDA	Digital signal
5	I ² C SCL	Digital signal
6	Vcc	3.3 V

Figure 4: Electrical flex connections of the EL-16-40 basic version without adapters.

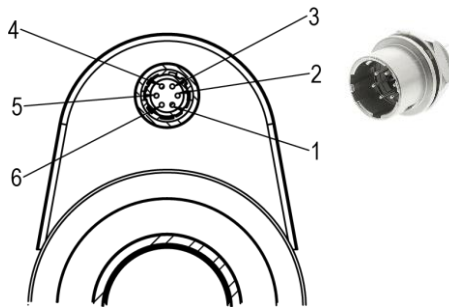

Pin out Hirose connector HR10G-7R-6PB(73)		
Position	Function	Sensor pins
1	Max. control current +	-
2	Max. control current -	-
3	GND	1-4
4	Vcc	8
5	I ² C SCL	6
6	I ² C SDA	5

Figure 5: Electrical connections of lens models without embedded controller featuring (male) Hirose connector.

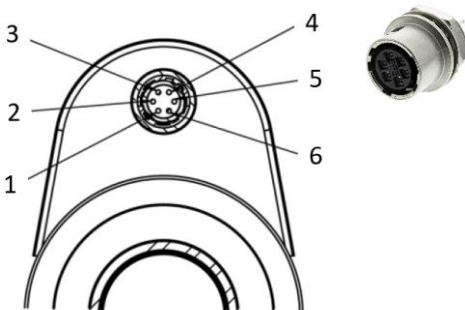

Pin out Hirose connector HR10G-7R-6SB(73)		
Position	Function	Value
1	GPIO Trigger	-
2	Analog In	0-10V
3	UART Tx / I ² C SCL	TTL
4	UART Rx / I ² C SDA	TTL
5	GND	-
6	Vcc	5-24V

Figure 6: Electrical connections of lens models with embedded controller ECC-1C featuring (female) Hirose connector.

Focal power versus current

The focal power of the EL-16-40 increases with positive and decreases with negative current as shown in Figure 7. When driving the lens up to absolute maximum control current, the tuning range increases further but significant heat generation must be considered.

Note that when the lens is rotated a gravity induced shift of 0.15 ± 0.01 dpt needs to be taken into account (difference between liquid lens facing up vs. down).

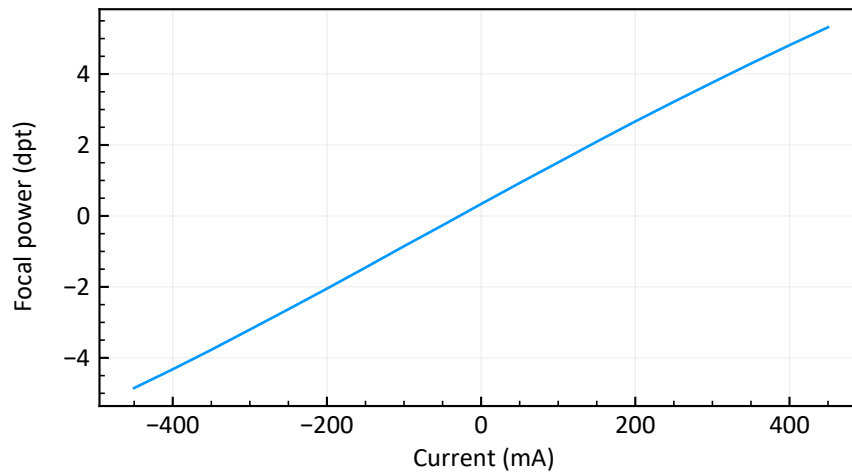

Figure 7: Typical data showing the relation between focal power (in diopters) and electrical current.

Transmission

Both the optical fluid and the membrane material are highly transparent in the range of 400 to 2500 nm. As the membrane is elastic it cannot be coated using standard processes, hence a reflection of 3 – 4% is to be expected. Cover glasses can be coated as desired. Figure 8 shows the transmission spectrum for the standard broad-band coatings.

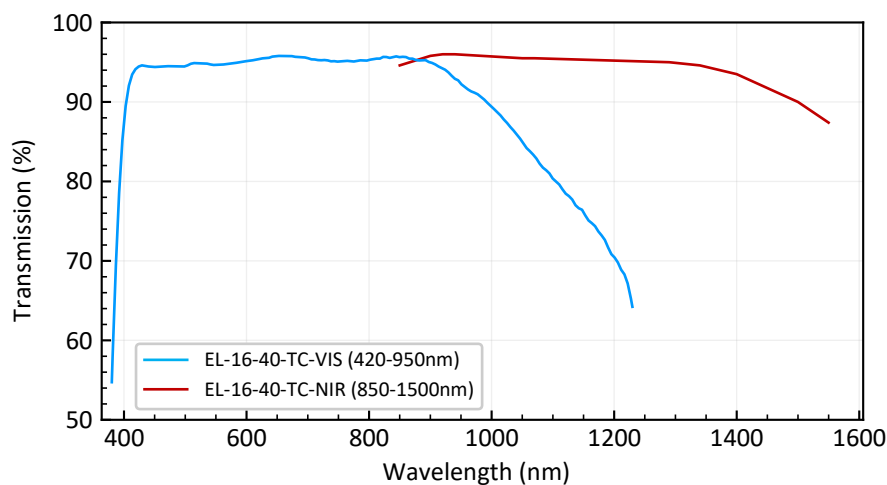

Figure 8: Transmission spectra of EL-16-40 with standard VIS & NIR coated glasses.

Wavefront quality

Figure 9 shows the typical wavefront error as a function of focal power. The wavefront quality varies from lens to lens and can be specified differently upon request, whereas the current standard specification is 0.15λ RMS for class 1 and 0.25λ RMS for class 2 lenses, respectively, with vertical optical axis.

When using the lens standing upright (optical axis horizontal) a Y-coma term must be added, whereas the following two options are available:

- EL-16-40-TC: Gravity induced coma in the order of 0.5λ RMS
- EL-16-40-GTC: Gravity induced coma of less than 0.05λ RMS

The gravity compensation technology applied is purely passive, settles within about 1 second upon a 90° rotation of the lens and has no adverse effects on any other specification.

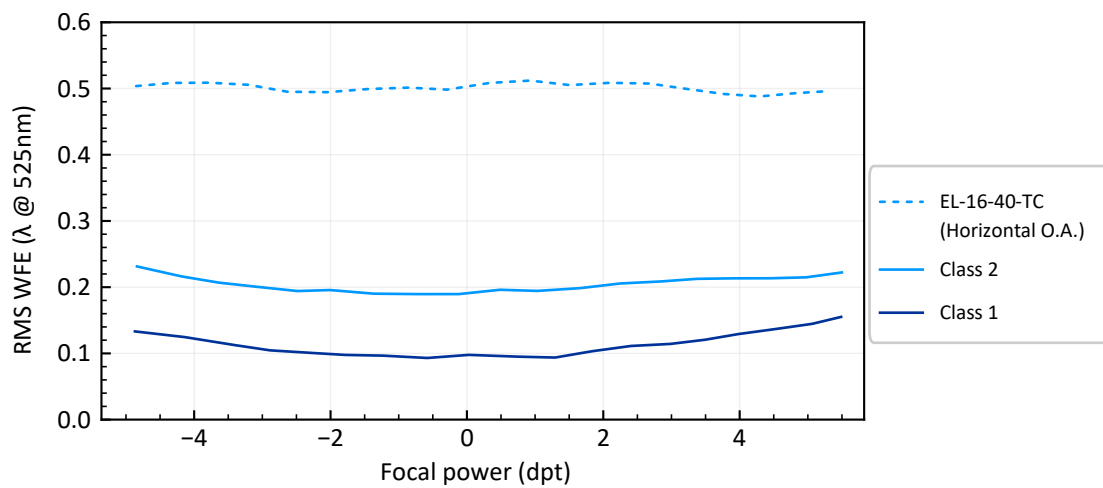

Figure 9: Typical wavefront error of the EL-16-40 vs focal power (@525nm, measured over 80% of the clear aperture, defocus, tilt and sphere excluded).

Response time

The rise time when applying a current step is about 5 ms. However, it takes about 20-25 ms until the higher order oscillations of the lens have fully settled. Figure 10 shows the optical response for several current steps measured at room temperature. Optotune controllers can provide appropriate signal conditioning which is able to halve the settling time, as shown in Figure 11. For more information, please contact sales@optotune.com.

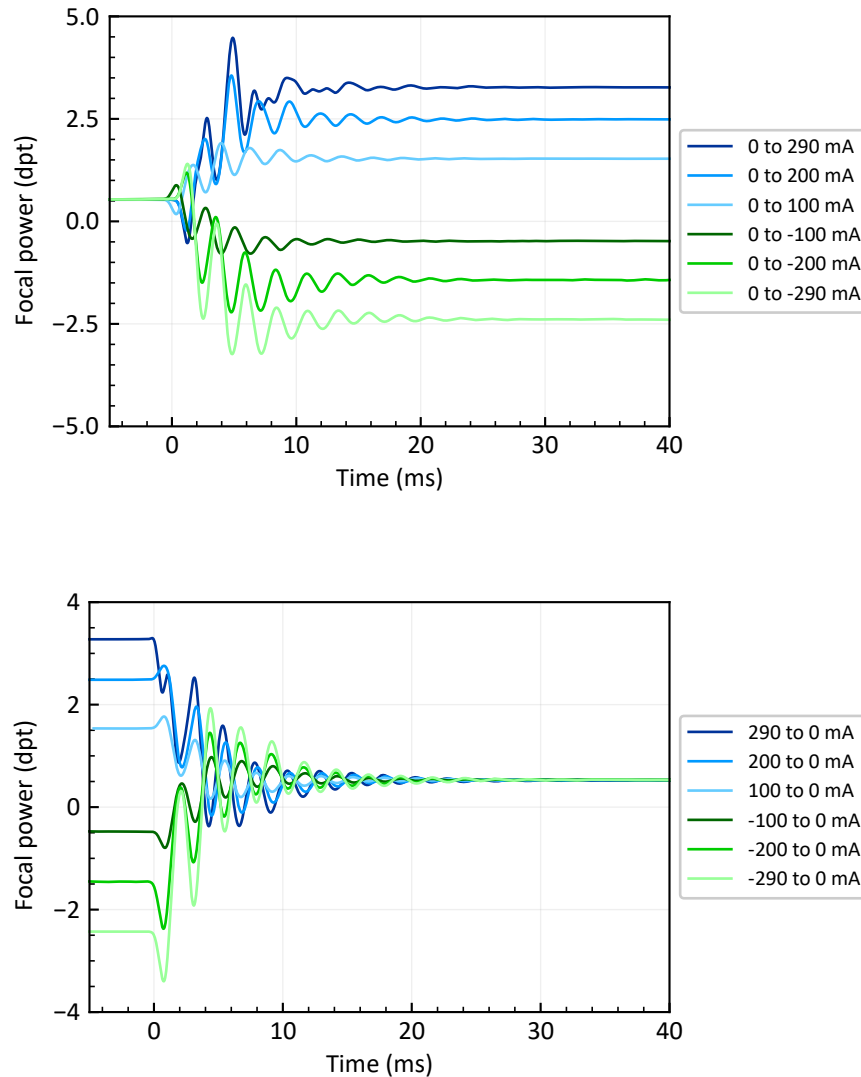

Figure 10: Typical optical response of the EL-16-40-TC-VIS-5D for several current steps. The upper plot shows a series of steps from low to high current and the lower plot for steps from high to low current.

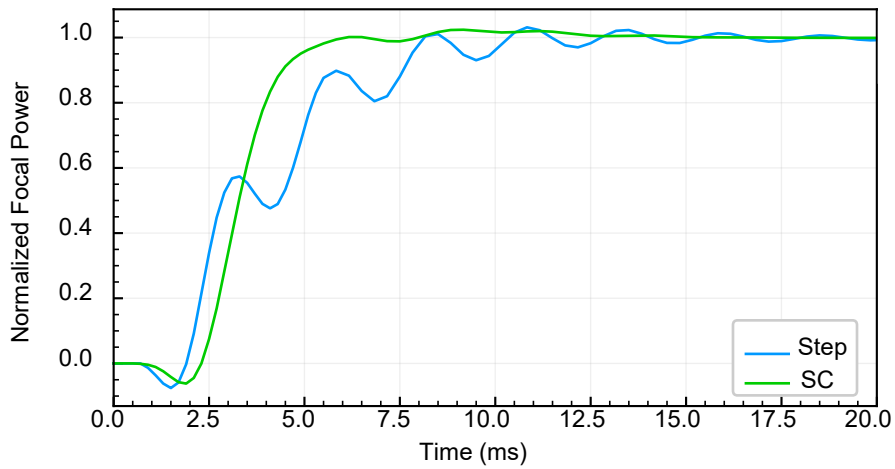

Figure 11: Optotune controllers can significantly reduce the settling time by providing signal conditioning (SC)

The frequency response over a broad range is presented in Figure 12, showing a resonance peak at 400 Hz. Note that this resonance is from a higher order mode, which can generally not be used for imaging over the entire clear aperture. When applying a current step, it is recommended to damp frequencies above 200 Hz range by using a low pass filter. This avoids excitation oscillations as seen in Figure 9.

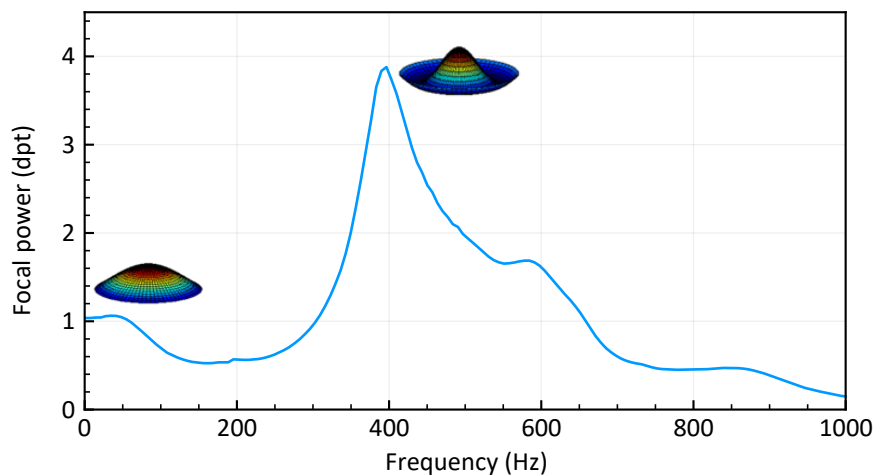

Figure 12: Typical frequency response of the EL-16-40-TC. The driving amplitude is -50 to 50 mA.

Temperature effects

Residual temperature effects influence the long-term drift of optical power stated in the specification table. These temperature effects are quantified by the temperature sensitivity S (dpt/°C), giving the change in optical power per degree Celsius. As shown in Figure 13, there is an almost linear dependence of S with optical power. Generally, temperature effects can be minimized when the EL-16-40 is thermally connected to a heat sink. The mounting itself can be used as a heat sink. Large mass and high thermal conductivity of the material dissipates the heat more efficiently. Optotune's Lens Controllers and Gardasoft's TR-CL180 use the integrated temperature sensor and calibration data to offer automatic compensation of this thermal drift.

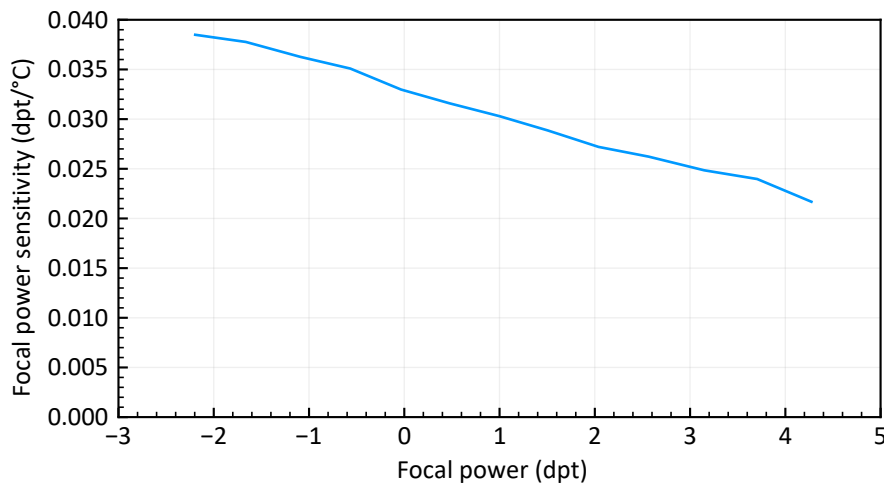

Figure 13: Temperature sensitivity as a function of focal power.

As the viscosity of the lens' liquid changes with temperature, the response varies as shown in Figure 14. Note that at very low operating temperatures it is possible to apply up to 500mA of current to the EL-16-40 to heat up the lens by about 10-20°C.

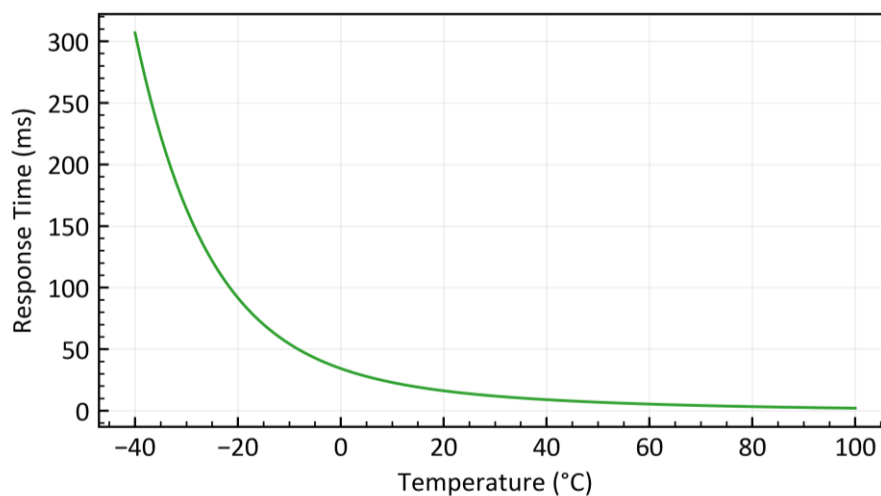

Figure 14: Response time in function of lens temperature.

Repeatability measurement*

To verify the lens repeatability performance under demanding conditions we replicate different use cases of the liquid lens using Optotune’s ICC-4C. The different driving schemes are shown in Figure 15.

- A static test where the lens is tuned to several focal powers and held at each value for approximately 5 minutes.
- A dynamic test where the lens is randomly tuned.
- A dynamic test where the lens is randomly tuned, with “resets” to 0 mA in between adjacent random jumps.

Each of these tests is performed using an input current range of either +/- 50 mA or +/- 200 mA, respectively; furthermore, the driving schemes are applied both with a stable controlled temperature of 30 °C, as well as with an increase of 15 °C lasting approximately 15 minutes, to test Optotune’s thermal compensation (focal power mode). For brevity, only the tests performed with a current range of +/- 50 mA at 30 °C are shown in Figure 15. The deviation of focal power (in green) represents the repeatability and is the difference between measured and set focal power.

Figure 16 summarizes the results of the repeatability tests in the form of a bar chart, showing the standard deviation (SD) of the focal power deviation for all combinations of driving scheme, current range and lens temperature.

- For all testing conditions, the repeatability (SD) is well below 0.020 dpt (20 mdpt).
- For all driving schemes and both current ranges, the repeatability (SD) is below 0.010 dpt (10 mdpt), when the test is performed at a stable temperature of 30 °C.
- For all driving schemes, when a range of +/- 50 mA is used (this corresponds to ≈ 1.5 dpt) at a stable temperature of 30 °C, the repeatability (SD) is lower than 0.005 dpt (5 mdpt).

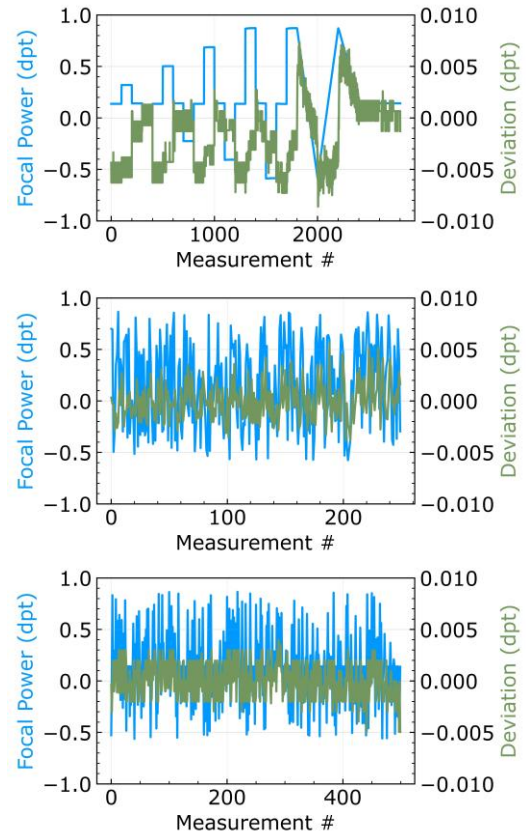

Figure 15: Driving schemes of repeatability tests (static, random, and random holds with resets at 0 mA)

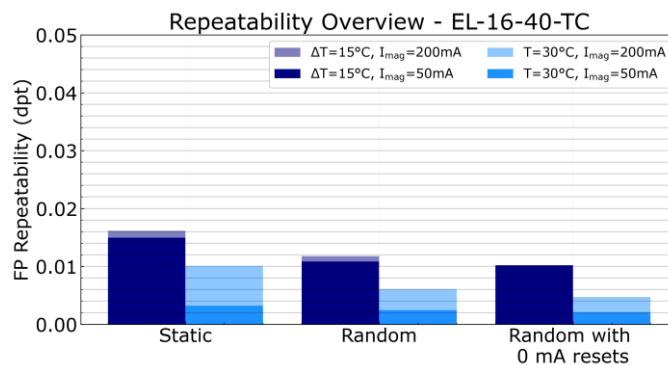

Figure 16: Summary of the repeatability test results (SD for the different combinations of driving scheme, current range, and lens temperature).

* The following results are representative of the repeatability performance of Class 1 lenses. Expect different performance for Class 2 lenses. Furthermore, they represent repeatability within a 10-hour period. To achieve similar performance through product lifecycle periodic in-situ recalibration might be required. For more information, contact sales@optotune.com.

In our [repeatability white paper](#), a concrete, real-life machine vision case using a 2x telecentric lens with very shallow depth of field with EL-16-40-TC, shows how a repeatability of +/- 10 mdpt is achieved.

Lifetime and reliability

The EL-16-40 has passed the environmental and accelerated aging tests as outlined in Table 1. When applicable the tests have been aligned with ISO 9022: Optics and photonics – Environmental test methods.

Test	ISO	Status
Mechanical cycling 200 million full range cycles (standard cycling -280mA to +280mA @ 50 Hz Sinusoidal)	-	Pass, continued test ongoing
Dry heat exposure, operating 63±2 °C, rel. humidity <40%, Cycling at -280mA to +280mA @50Hz step, 16 Hrs.	9022-11-04-2	Pass
Cold exposure, operating -35°C ± 3°C, Cycling at -280mA to +280mA @1Hz step, 16 Hrs.	9022-10-07-2	Pass
Dry heat exposure, storage 85±2 °C, rel. humidity <40%, non-operating, 2Hrs.	9022-11-08-1	Pass
Cold exposure, storage -40±3 °C, non-operating, 16Hrs.	9022-10-08-1	Pass
Damp heat exposure 55±2 °C, rel. humidity 90% to 95%, 16Hrs.	9022-12-07-1	Pass
Temperature Shock -40 to 55 °C, 2.5h/cycle, <20s transition time, 5 cycles	9022-15-03-1	Pass
Solar radiation 55°C ± 2°C, 1120 W/m ² , 10 days	9022-9-04a	Pass
Mechanical Shock 100g, 6ms, 3 shocks along each axis	9022-30-07-1	Pass
Response time Full step Lens response	-	Pass
Cycle Repeatability	-	Pass

Table 1: Reliability and lifetime testing of the EL-16-40

Optical layout

Zemax simulations to model the EL-16-40 lens series within an optical design are available at this [link](#).

Autofluorescence, birefringence & polarization effects

The EL-16-40 is neither auto-fluorescent, birefringent or in any other way polarization dependent.

Safety and compliance

The product fulfills the RoHS and REACH compliance standards. The customer is solely responsible to comply with all relevant safety regulations for integration and operation.

For more information on optical, mechanical, and electrical parameters, please contact sales@optotune.com

Packaging

The EL-16-40 industrial version is available in single units packaged in a box. The EL-16-40 OEM version is available in single units packaged in a membrane box or in trays of 25 units each.

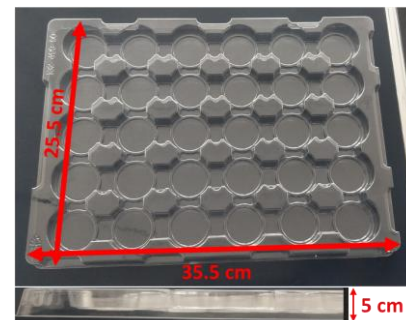

Figure 17: Sizes of the 25 units tray for the OEM version.

Ordering information for EL-16-40

For custom versions, please use the following concept for part numbers:

EL-16-40-COMP-AR-DPT-CL-THR-CTRL

COMP = TC: Temperature compensated
GTC: Gravity and temperature compensated

AR = VIS: 420 – 950nm coated cover glasses
NIR: 850 – 1500nm coated cover glasses

DPT = 5D: 5 diopter focal power range
20D: 20 diopter focal power range

CL = 1: class 1 specification for wavefront error

THR = C: C-mount thread
M25.5: M25.5x0.5 thread
M26: M26x0.706 thread
M27: M27x0.5 thread
M30.5: M30.5x0.5 thread
M42: M42x1 thread

CTRL = E: Includes embedded lens controller ECC-1C