

ELM-12-2.8-18-C



Lens module specifications

Effective focal length	12	mm	
F/#	2.8	(Variable)	
Maximum sensor format	1.1	inch	
Maximum image circle (Φ)	18	mm	
Lifecycles (10-90% sinusoidal)	>1'000'000'000	cycles	
FOV			
	Horizontal	66.6	°
	Vertical	47.8	°
Back Focal Length	-	mm	
Optical Distortion	< -7.1	%	
Pixel size recommended	2.4	μm	
Wavelength range	400-700	nm	
Relative illumination	64	%	
Max chief ray angle	-	°	
Working distance range	150 - infinity	mm	
Mount	C-mount		
Filter thread	M40.5 x 0.5		
Total Track Length	-	mm	
Dimension (Φ x L)	47 x 64	mm	

Electrical specifications

Control current (typical)	-250 to +250	mA	
Absolute max. control current	-500 to 500	mA	
Power consumption	0 to 0.7 (nominal) 0 to 2.8 (absolute max.)	W	
Motor coil resistance @ 30°C	12	Ω	
Absolute maximum voltage (coil)	10	V	
Absolute maximum voltage (temp. sensor)	4.3	V	

Focus tunable lens specifications

EL-16-40-TC-VIS-5D-C

Focal power range (@30°C) ³	-2 to +3	dpt	
Wavefront error (at 525 nm&0mA)	<0.25/<0.5	λRMS	
Optical axis vertical / horizontal			
Operating temperature	-20 to +65	°C	
Storage temperature	-40 to +85	°C	
Temperature sensor & memory	STTS2004		(STMicroelectronics)

Hirose connector (HR10G-7R-6P)

	Function	Sensor pins
Pin 1	Control current +	-
Pin 2	Control current -	-
Pin 3	Ground	1-4
Pin 4	Power (3.3V)	8
Pin 5	I ² C SCL	6
Pin 6	I ² C SDA	5

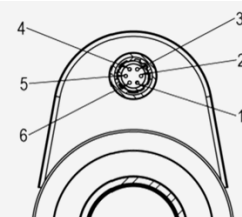

Controller

The liquid lens is controlled with electrical current and must be operated by a suitable lens controller. Hirose cables and liquid lens controllers are sold separately. The following controllers are considered fully compatible with ELM-12-2.8-18-C:

- Optotune embedded controller ECC-1C
- Optotune lens driver EL-E-4i
- Optotune industrial controller ICC-4C-500



Additional selection of controllers is available at www.optotune.com/controllers

Mechanical drawings

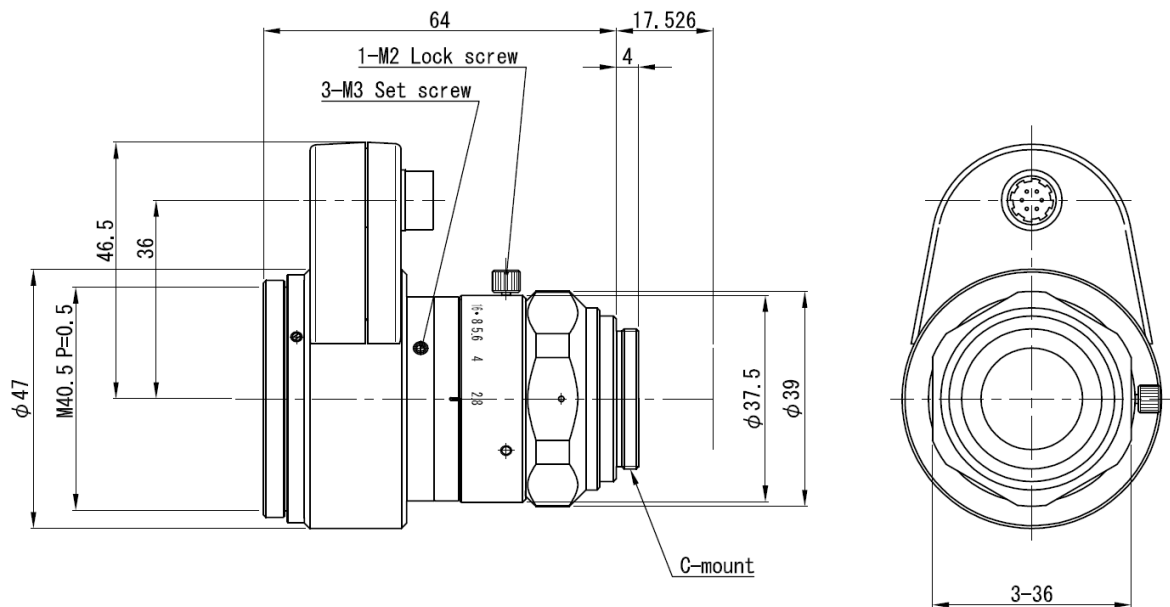

Figure 1: Mechanical drawing of the ELM-12-2.8-18-C

For more information on optical, mechanical and electrical parameters, please contact sales@optotune.com.