

ELM-25-3.2(3.7)-18-C



Optotune's lineup of electrically tunable lens modules provides optically optimized, integrated solutions that simplify the design of vision systems. The ELM-F series consists of entocentric lens modules designed for best performance, compactness, camera compatibility, and ease of use.

The ELM-25-3.2(3.7)-18-C is a C-mount entocentric lens module designed around the focus tunable lenses EL-12-30 and EL-7-20. The module is compatible with camera formats up to 1.1". It offers:

- A focus tunable lens in an optimized optical and mechanical design
- Working distance range of 200 mm to infinity
- Best performance-to-price ratio
- Option for integrated lens controller, compatible with several camera brands

Lens module specifications

	EL-12-30-TC-VIS-16D	EL-7-20-TC-VIS-14D	
Effective focal length		24.5	mm
F/# (fixed)	3.2	3.7	
Maximum sensor format		1.1	inch
Maximum image circle (Φ)		18	mm
Lifecycles (10-90% sinusoidal)		>1'000'000'000	cycles
FOV for 1.1" sensor	Diagonal	40.0	°
	Horizontal	28.8	°
	Vertical	28.8	°
Back focal length (BFL)		13.53	mm (in air)
Optical distortion		<0.5	%
Pixel size (recommended)		2.74	μm
Wavelength range		420-900	nm
Relative illumination	>86	>89	%
Max chief ray angle	10.2	9.5	°
Working distance (WD) range ¹		200 to inf	mm
Optimal WD		1000	mm
WD at 0 dpt		inf	mm
Mount		C-mount	
Filter thread		M49x0.5	
Connector type		Hirose (6 pins)	
Total track length (TTL)		142.5	mm
Dimension (Φ x L)		60.2 x 129.0	mm
Weight		555	g
Operating temperature		-20 to +65	°C
Storage temperature		-40 to +85	°C

¹ For working distances below 200 mm, a XX mm spacer is recommended.

Focus tunable lens specifications

	EL-12-30-TC-VIS-16D	EL-7-20-TC-VIS-14D	
Focal power range (@25°C)	-6 to +10	-6 to +8	dpt
Focal power range for module WD range	0.0 to +3.6		dpt
Temperature sensor and EEPROM	Yes		
Control current (typical)	-250 to +250		mA
Max. control current	-300 to +300		mA
Motor coil resistance @ 30°C	15	12	Ω
Absolute maximum voltage (coil)	6	6	V

Embedded controller specifications²

Supply voltage range	5 and 9-24 (tolerance ± 5%)	VDC
Maximum power consumption (5V / 9-24V)	1.5 / 2.5	W
Analog voltage inputs level	0-10	V
Digital signal logic level	3.3	V

Overview of available standard products

Standard Product	F/#	Connector	Controller	Typical interface
ELM-25-3.2-18-C	F/3.2	Hirose (male)	ICC-1C, ICC-4C-500 (not included)	USB, Ethernet, Analog 0-10 V
ELM-25-3.2-18-C-E	F/3.2	Hirose (female)	ECC-1C (embedded)	I2C, UART, Analog 0-10 V UART to USB cable available.
ELM-25-3.7-18-C	F/3.7	Hirose (male)	ICC-1C, ICC-4C-500 (not included)	USB, Ethernet, Analog 0-10 V
ELM-25-3.7-18-C-E	F/3.7	Hirose (female)	ECC-1C (embedded)	I2C, UART, Analog 0-10 V UART to USB cable available.

Control

The focus tunable lens is controlled with electrical current and must be operated by a suitable lens controller. The following controllers are fully compatible:

- Optotune embedded controller ECC-1C (included in -E configuration, compatible with selected cameras)
- Optotune industrial controller ICC-1C
- Optotune industrial controller ICC-4C-500



Further information about Optotune's controllers is available at www.optotune.com/controllers.

² Applies to the -E version of the ELM. For more information, please refer to the [ECC-1C datasheet](#).

Electrical layout

Hirose connector (HR10G-7R-6PB)	Function	Sensor pins
Pin 1	Control current +	-
Pin 2	Control current -	-
Pin 3	Ground	1-4
Pin 4	Vcc (3.0-3.7V)	8
Pin 5	I ² C SCL	6
Pin 6	I ² C SDA	5

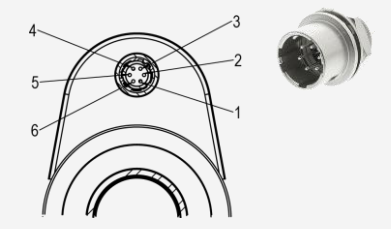

Table 1: Pinout of the ELM-25-3.2(3.7)-18-C Hirose connector (for external controller).

Hirose connector (HR10G-7R-6SB)	Function	Value
Pin 1	GPIO Trigger	-
Pin 2	Analog In	0-10V
Pin 3	UART Tx / I ² C SCL	TTL
Pin 4	UART Rx / I ² C SDA	TTL
Pin 5	GND	-
Pin 6	Vcc	5-24V



Table 2: Pinout of the ELM-25-3.2(3.7)-18-C-E Hirose connector (ECC-1C controller integrated).

Mechanical layout

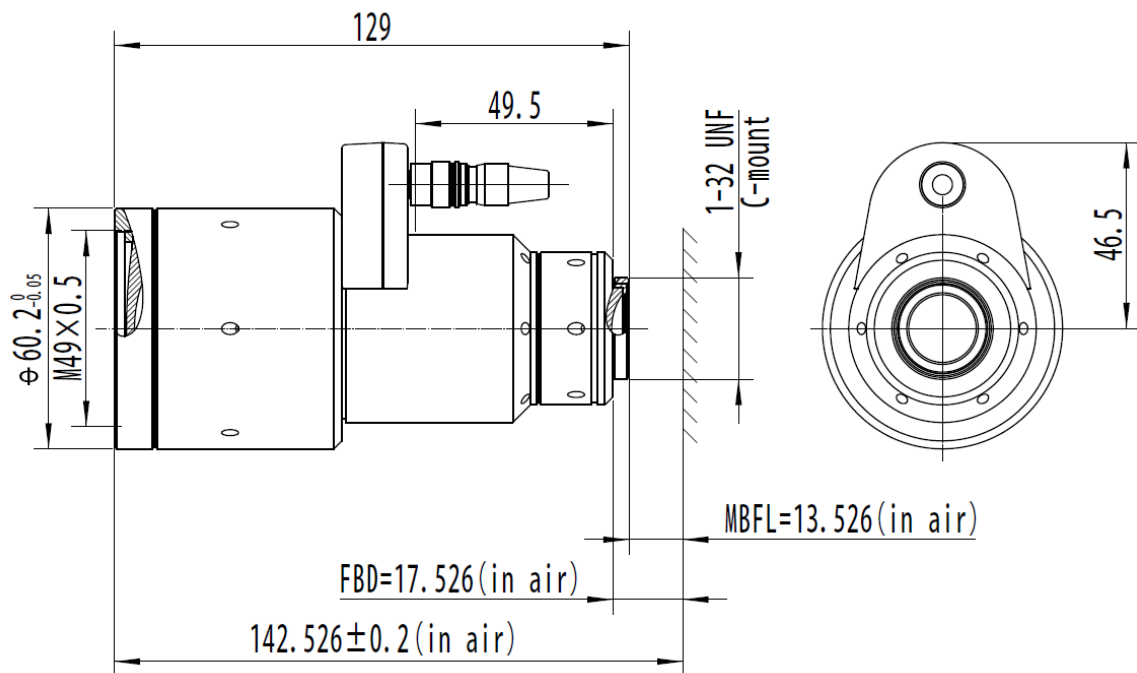

Figure 1: Mechanical drawing of the ELM-25-3.2(3.7)-18-C (unit: mm).

Relative illumination and distortion

The relative illumination and distortion of ELM-25-3.2-18-C (f/3.2) is shown in Figure 2 and of ELM-25-3.7-18-C (f/3.7) in Figure 3.

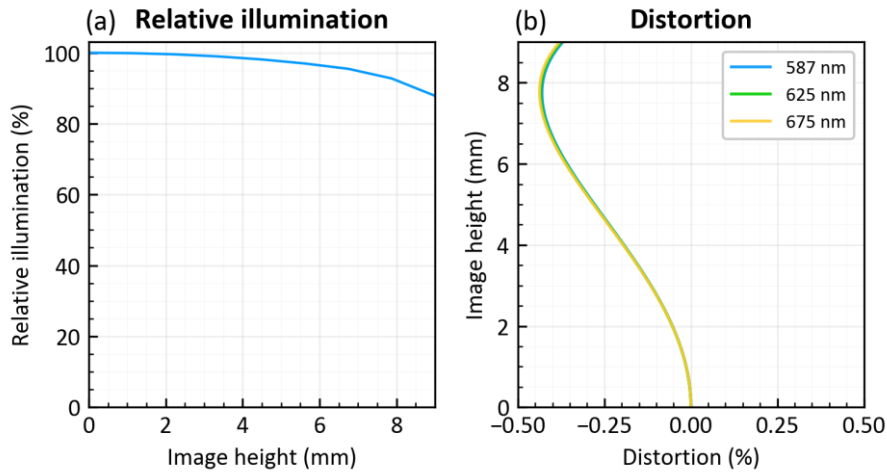

Figure 2: (a) Relative illumination for 525 nm. (b) Image height vs. distortion. Data for ELM-25-3.2-18-C.

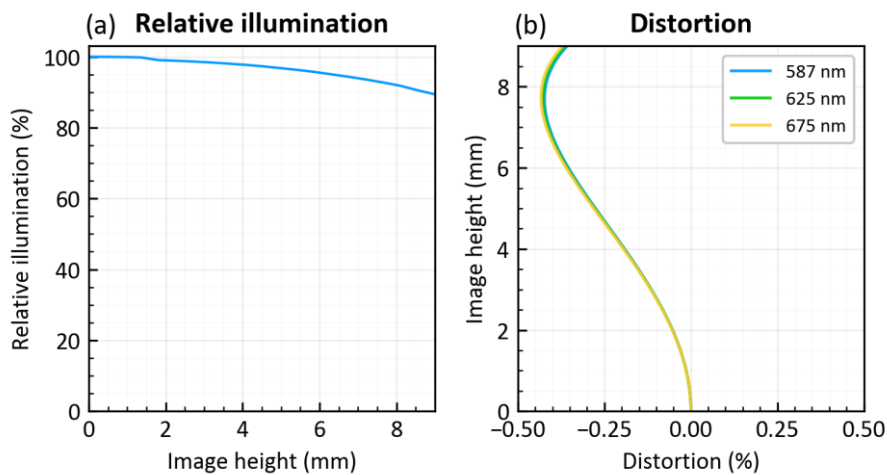

Figure 3: (a) Relative illumination for 525 nm. (b) Image height vs. distortion. Data for ELM-25-3.7-18-C.

Modulation transfer function (MTF)

The simulated optimal MTF at WD=500 mm (no focus tunable lens aberrations included) of ELM-25-3.2-18-C (f/3.2) is shown in Figure 4 and of ELM-25-3.7-18-C (f/4.0) in Figure 5.

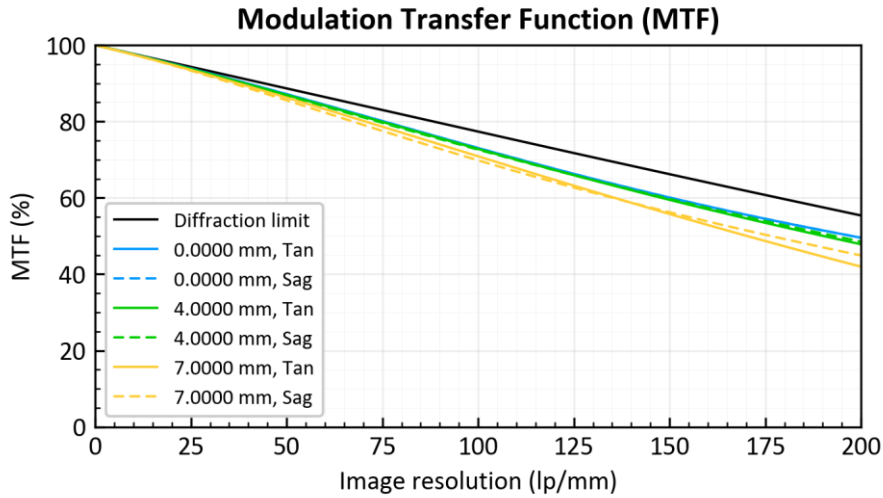

Figure 4: ELM-25-3.2-18-C MTF at WD = 500 mm and $\lambda = 425-675\text{nm}$.

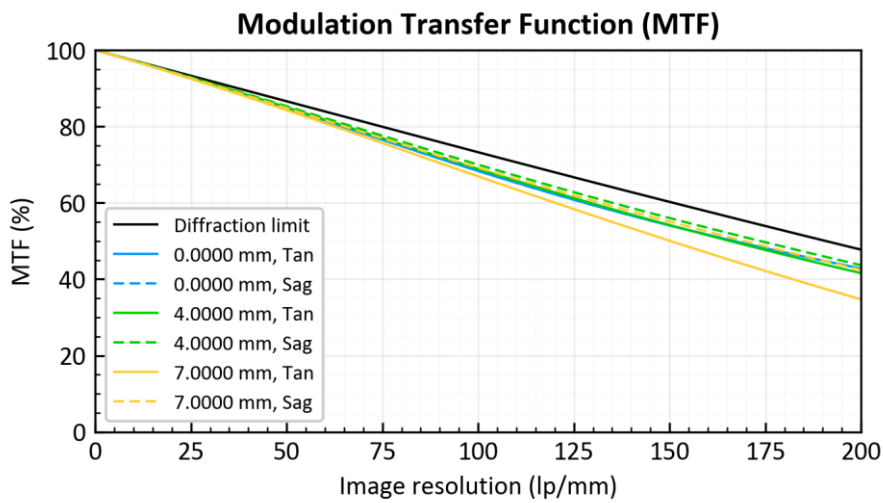

Figure 5: ELM-25-3.7-18-C MTF at WD = 500 mm and $\lambda = 425-675\text{nm}$.

Safety and compliance

The product fulfills the RoHS and REACH compliance standards. The customer is solely responsible for complying with all relevant safety regulations for integration and operation, including EMC compliance.

For more information on optical, mechanical, and electrical parameters, please contact sales@optotune.com.