

Electrically tunable lens EL-7-20-TC

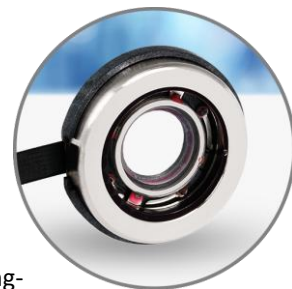

The compact EL-7-20-TC lens is designed for OEM integration into optical systems for various applications. The working principle is based on the well-established shape-changing lens technology. The curvature of the lens is adjusted by applying an electrical current. Thereby, the focal length is tuned to a desired value within a few milliseconds. The lens architecture is “push pull” which means that the lens curvature is deflected from concave to convex. With actuators based on proven voice-coil technology, the EL-7-20-TC focus tunable lens is extremely reliable and robust, well suited even for applications in harsh environments over large temperature ranges.

Lens specifications

Clear aperture	7.0	mm
Focal power range: (25°C, ±250 mA)	-6 to +8	dpt
Focal power @ 0 mA (25°C, typical)	0 to +2.5	dpt
Transmission range	VIS: 420 to 950	nm
Wavefront error @ 0 dpt (Optical axis vertical / horizontal)	class 1: 0.07 / 0.085 class 2: 0.10 / 0.11	λ RMS @ 532 nm
Lens type	plano-concave to plano-convex	
Refractive index / Abbe number	$n_D = 1.45 / v = 55$	
Lens centration to outer diameter	0.15	mm
Response time (10% - 90%) (typ. at 25°C, 0 to ±250 mA step)	1	ms
Settling time (typ. at 25°C, 0 to ±250 mA step, ±0.1 dpt)	7 (with signal conditioning) 20 (rectangular step)	ms
Lifecycles (-200mA to + 200mA, sinusoidal, 20Hz)	> 1'000'000'000	
Operating temperature	-20 to 65	°C
Storage temperature	-40 to 85	°C
Weight	3.15	g

Electrical specifications

Nominal control current	-250 to 250	mA
Absolute max. control current	-300 to 300	mA
Motor coil resistance @ 25°C	14	Ω
Power consumption for 5 dpt range (±60mA)	50	mW
Max power consumption (@ 250 mA)	875	mW
Memory	ON Semiconductor: CAT24C64C4CTR (or similar)	
Temperature sensor	Maxim Integrated: MAX31875R2TZS+T (or similar)	
Absolute maximum voltage (coil)	6	V
Absolute maximum voltage (memory & sensor)	4	V

Overview of available standard products

Standard Product	Tuning Range	Wavefront error	Prism	Wavelength range
EL-7-20-TC-VIS-14D-1	-6 to 8 dpt	0.07 λ RMS	0.1 dpt	420 – 950 nm
EL-7-20-TC-VIS-14D-2	-6 to 8 dpt	0.10 λ RMS	0.2 dpt	420 – 950 nm

Liquid lens working principle

The working principle of the EL-7-20-TC is based on Optotune’s well-established technology of shape-changing polymer lenses. The core that forms the lens contains an optical fluid, which is sealed off with an elastic polymer membrane as shown in Figure 1. An electromagnetic actuator is used to exert pressure on the container and therefore changes the curvature of the lens. By changing the electrical current flowing through the coil of the actuator, the focal power of the lens is controlled.

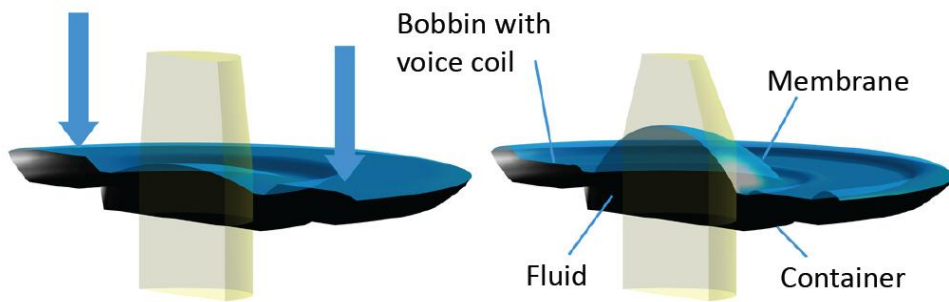

Figure 1: Working principle of the EL-7-20-TC.

Mechanical Layout

The EL-7-20-TC comes with a steel top return structure and an LCP base. The electrical connection and communication with the controller is established via an FFC cable at the side. The relevant mechanical drawings are depicted in Figure 2.

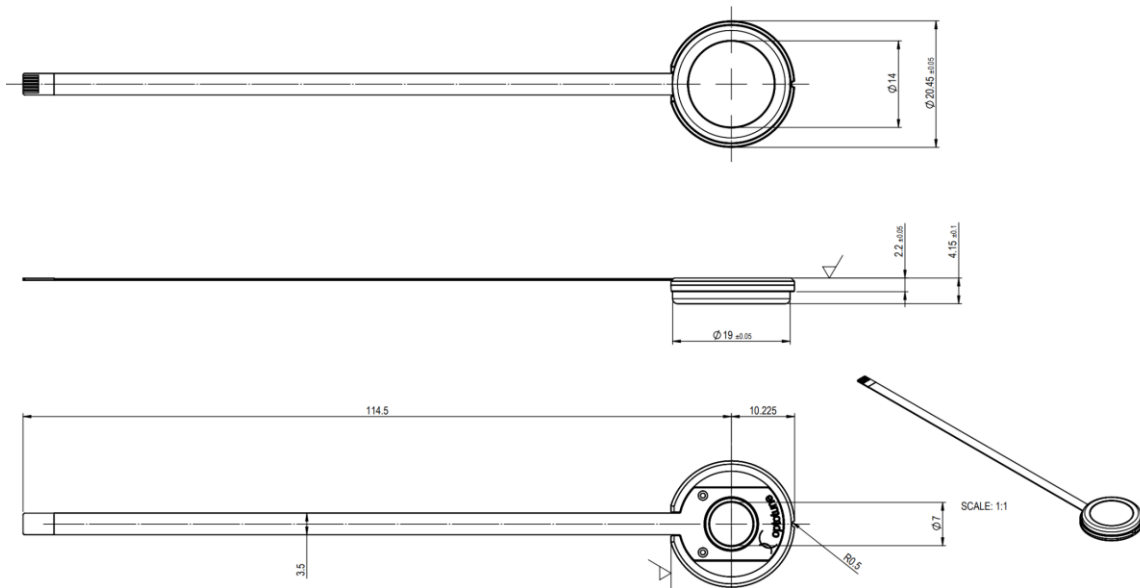

Figure 2: Mechanical drawing of the EL-7-20-TC-VIS-16D (unit: mm)

Warning: Do not hold the lens by the flex cable as it can be damaged

Electrical connection

The electrical connection of the EL-7-20-TC without adapters consists of a FPC flex cable with 6 pins suitable for Molex connector no. 503480-0600 or equivalent. Two pins are for the coil of the lens, the other four pins are for the I²C connection to the temperature sensor and EEPROM.

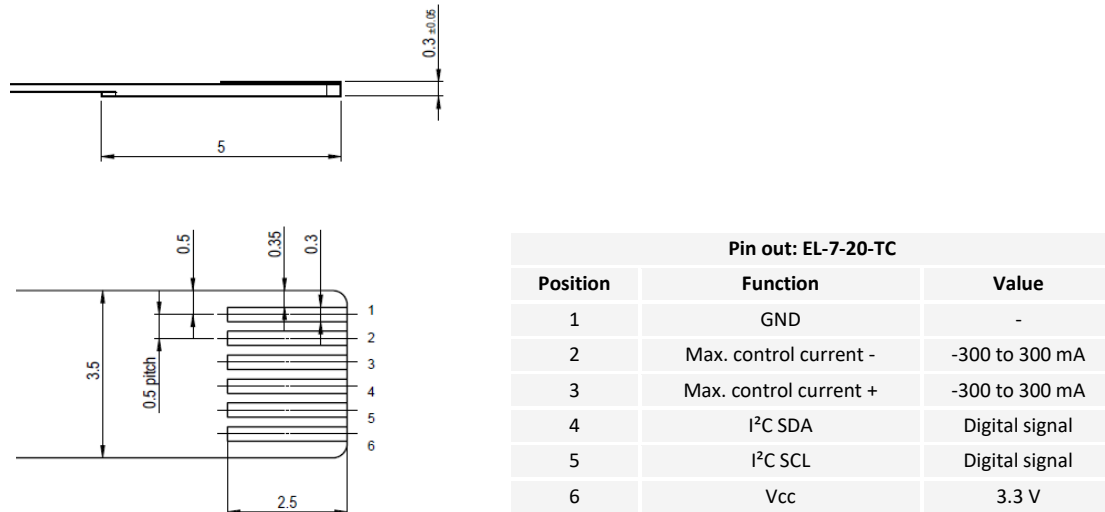

Figure 3: Electrical flex connections of the EL-7-20-TC

Component:	Temperature Sensor	EEPROM
I ² C Address	Maxim Integrated: MAX31875R2TZS+T	ON Semiconductor: CAT24C64C4CTR
BIN	0b 1001 010x	0b 1010 000x
HEX	W: 0x94; R: 0x95	W: 0xA0; R: 0xA1
DEC	W: 148; R: 149	W: 160; R: 161

Figure 4: Electrical components and addresses

Mounting possibilities for EL-7-20-TC

To mount EL-7-20-TC, it can be clamped on the flange. The LCP base is designed for retention of the lens in the direction of the optical axis.

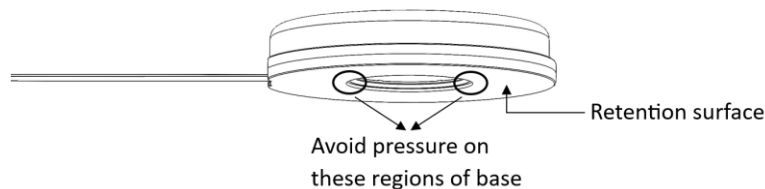

Focal power versus current

The focal power of the EL-7-20-TC increases with positive and decreases with negative current as shown in Figure 5. When driving the lens up to absolute maximum control current, the tuning range increases further but significant heat generation must be considered.

Note that when the lens is rotated a gravity induced shift of 0.22 ± 0.02 dpt per g needs to be taken into account (difference between liquid lens facing up vs. down is ~ 0.45 dpt).

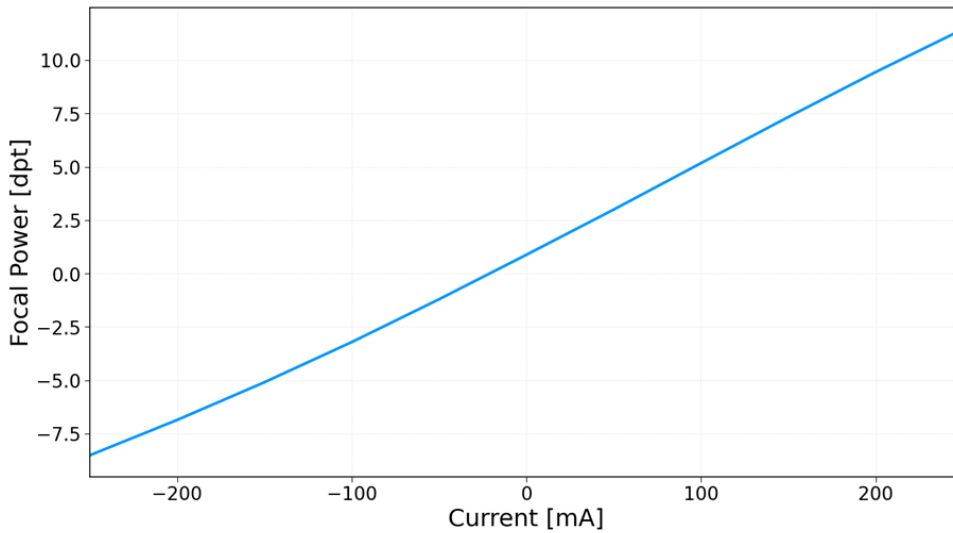

Figure 5: Typical data showing the relation between focal power (in diopters) and electrical current.

Transmission

Both the optical fluid and the membrane material are highly transparent in the range of 400 to 1700 nm. As the membrane is elastic it cannot be coated using standard processes, hence a reflection of 3 – 4% is to be expected. Cover glasses can be coated as desired.

Figure 6 shows the transmission spectrum for a VIS broad-band coating.

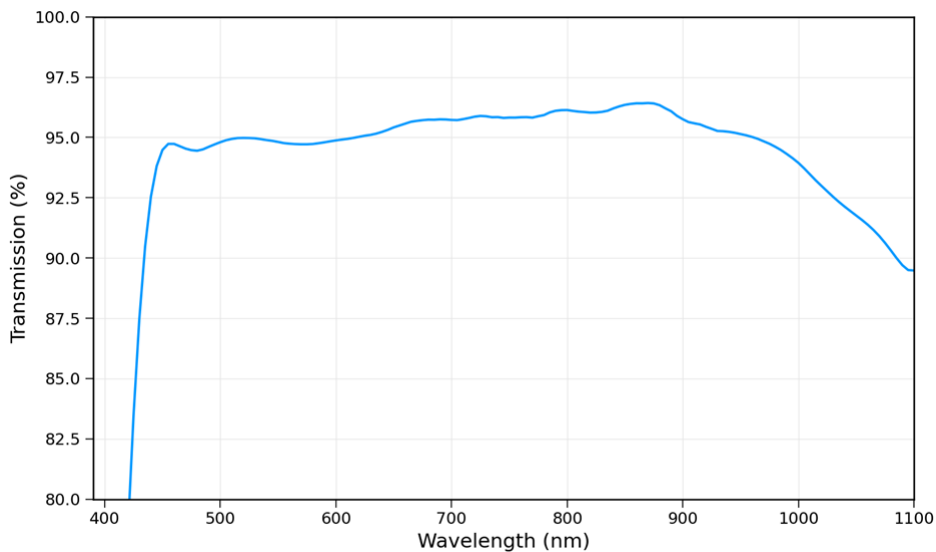

Figure 6: Transmission spectrum of standard EL-7-20-TC.

Wavefront quality for class 2 lenses.

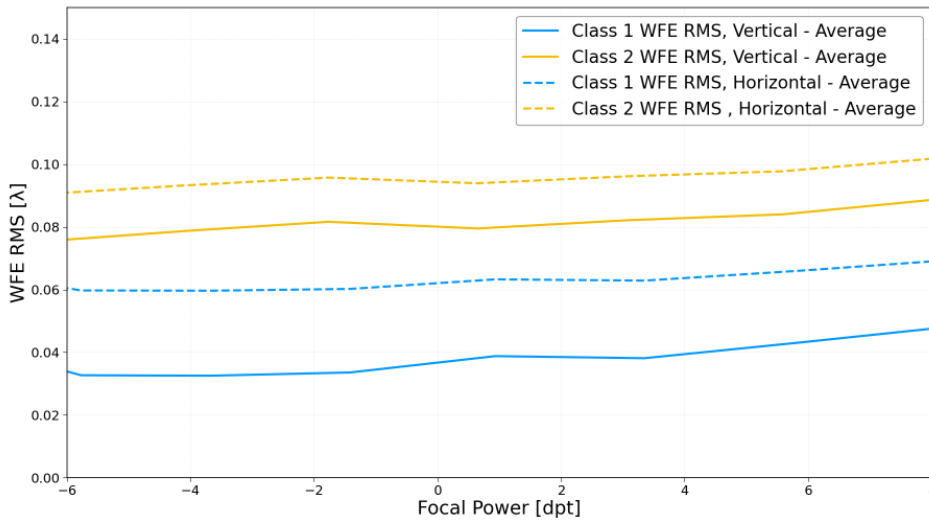

Figure 7 shows the typical wavefront error as a function of focal power. The wavefront quality varies from lens to lens can be specified differently upon request. Best optical performance is typically achieved between -2 and 4 diopters. When using the lens standing upright (optical axis horizontal) a Y-coma term in the order of 0.05 λ RMS must be added resulting in a total wavefront error in the order of 0.085 λ RMS for class 1 and 0.11 λ RMS for class 2 lenses.

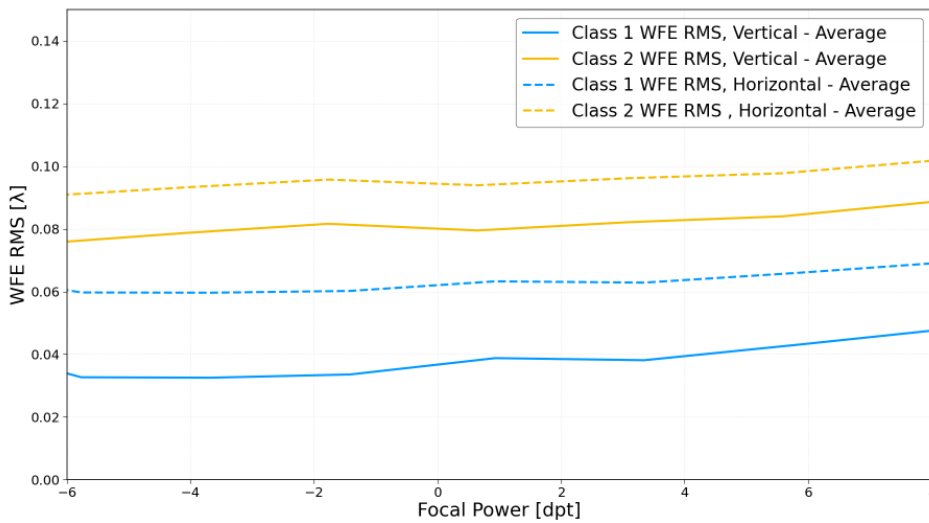

Figure 7: Typical wavefront error of the EL-7-20-TC versus focal power, showing average values for Class 1 and Class 2 lenses (530 nm wavelength, measured over 80% of the clear aperture).

Response time

The EL-7-20-TC exhibits a very fast response time of about 1 ms and a settling time of about 20 ms based on a rectangular step. Optotune controllers can provide appropriate signal conditioning which is able to more than halve the settling time, as shown in Figure 8.

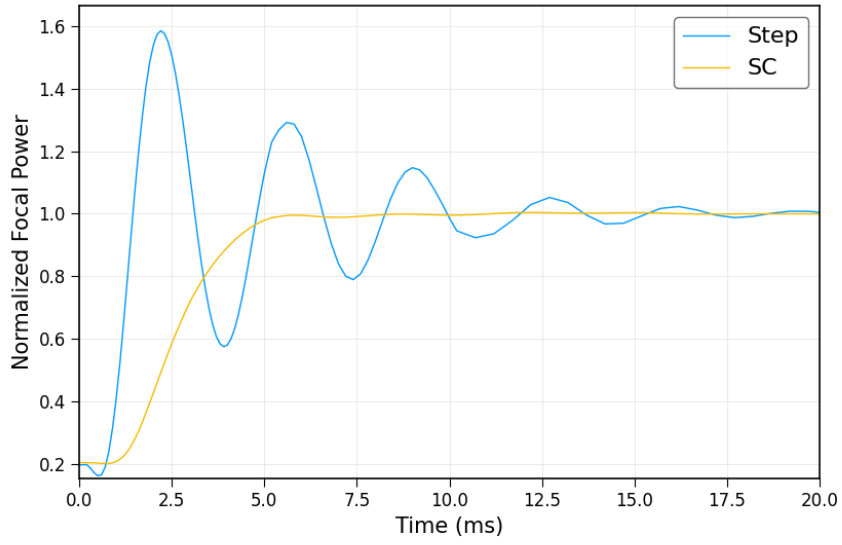

Figure 8: The settling time can be improved with signal conditioning (SC)

Figure 9 shows the focal power response for several current steps measured at room temperature.

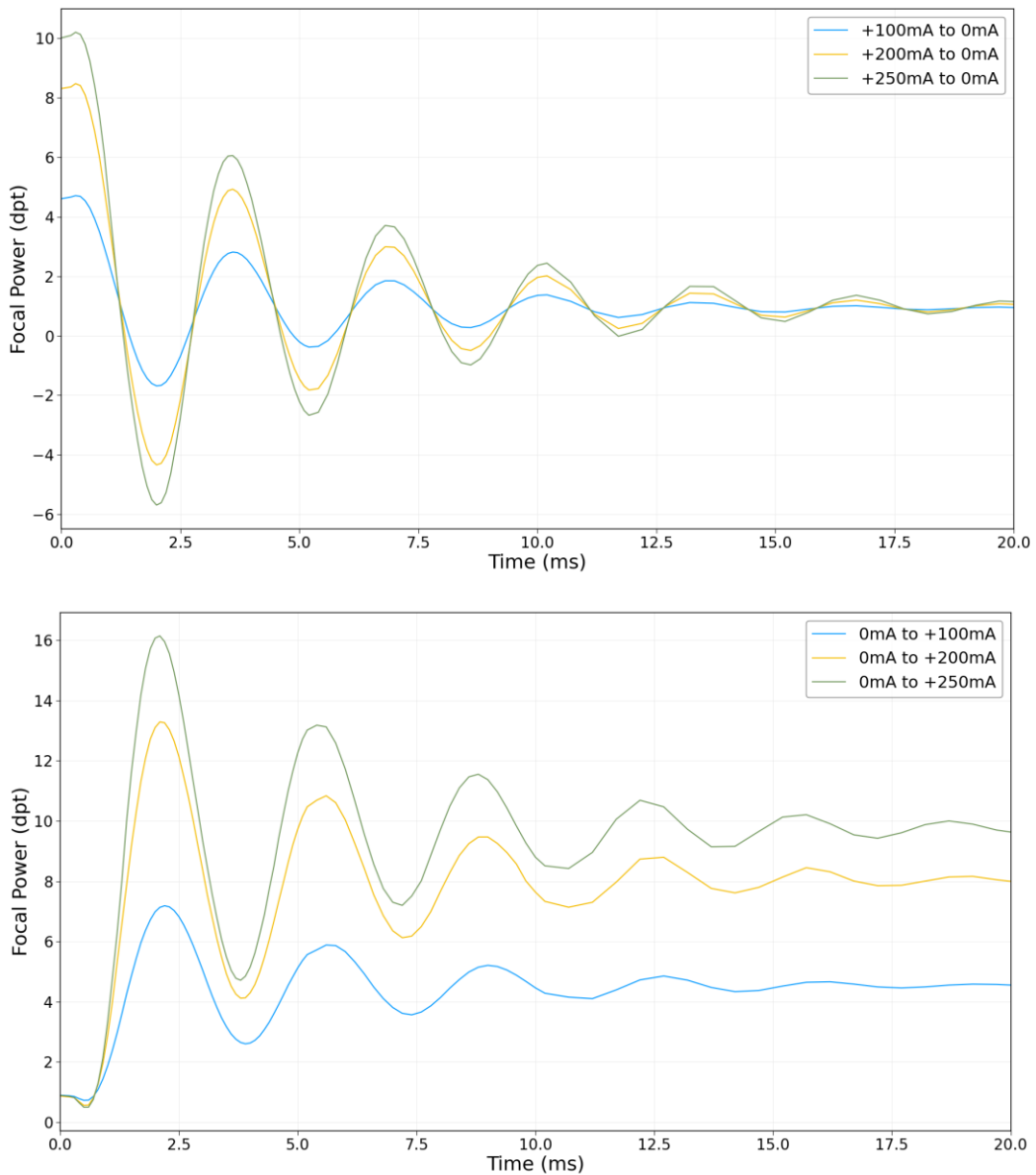

Figure 9: Typical focal power response of the EL-7-20-TC for several current steps. The upper plot shows a series of steps from high current to 0mA, and the lower plot for steps from 0mA to high current.

The frequency response is presented in Figure 10, showing a resonance peak at around 300 Hz. Due to the excitation of higher order modes, and the associated increase in wavefront error, the lens can generally not be used for imaging applications around the resonant frequency.

When applying a current step, it is recommended to damp frequencies above 200 Hz range by using a low pass filter. This avoids excitation oscillations as seen in Figure 9.

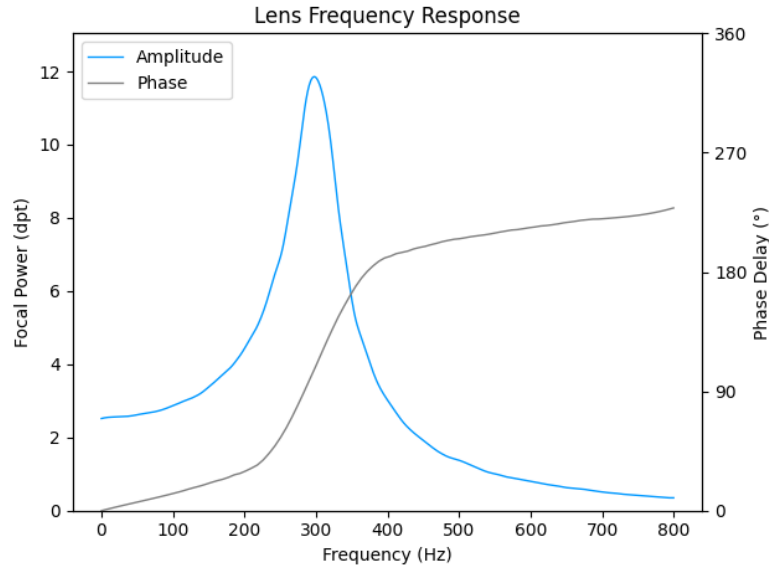

Figure 10 :Typical frequency response and phase delay of the EL-7-20-TC.

Temperature effects

Residual temperature effects influence the long-term drift of focal power stated in the specification table. These temperature effects are quantified by the temperature sensitivity S (dpt/°C), giving the change in focal power per degree Celsius. As shown in Figure 11, there is an almost linear dependence of S with focal power. Generally, temperature effects can be minimized when the EL-7-20-TC is thermally connected to a heat sink (large mass with high thermal conductivity).

Best thermal performance is achieved when operating the EL-7-20-TC in the range of 0 to 5 diopters.

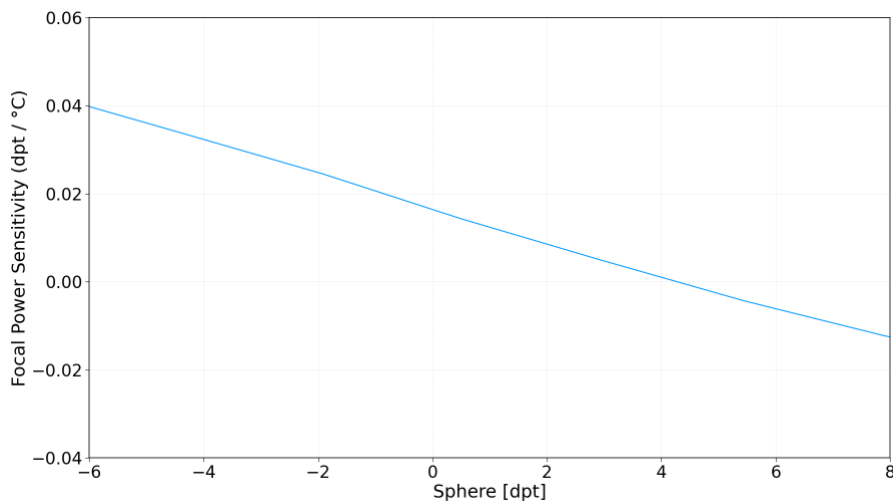

Figure 11: Temperature sensitivity as a function of sphere.

As the viscosity of the lens' liquid changes with temperature, the response varies as shown in Figure 12. Note that at very low operating temperatures it is possible to apply up to 300mA of current to the EL-7-20 to heat up the lens by about 10-20°C.

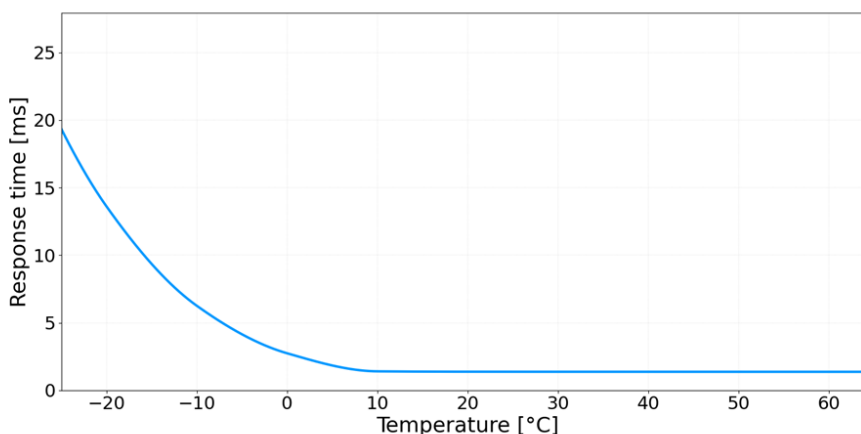

Figure 12: Response time in function of lens temperature.

Lifetime and reliability

The EL-7-20 has passed the environmental and accelerated aging tests as outlined in Table 1. When applicable we have aligned our tests with those defined by ISO 9022: Optics and photonics – Environmental test methods.

Test	ISO	Status
Mechanical cycling 100 million full range cycles: 1. -250mA to +250mA, f=20Hz, sinusoidal tuning profile 2. -200mA to +200mA, f=20Hz, rectangular tuning profile	-	Pass, continued test ongoing
Mechanical Shock F=500g, t=1ms, 3x6 shocks (3x along each axis)	9022-30-08-1	Pass
High Temperature Storage T=85±2 °C, rel. hum. <40%, t=2h	9022-11-08-1	Pass
Low Temperature Storage T=-40±2 °C, t=168h	9022-10-07-1	Pass
Damp Heat T=55±2 °C, rel. hum. 90% to 95%, t=16h	9022-12-07-1	Pass
Temperature Shock T=-45 to 55 °C, t=2.5 h/cycle, <20s transition time, 5 cycles	9022-15-03-1	Pass

Table 1: Reliability and lifetime testing of the EL-7-20-TC

Optical layout

Zemax simulations to model the EL-7-20 lens series within an optical design are available at this [link](#).

Autofluorescence, birefringence & polarization effects

The EL-7-20-TC is neither auto-fluorescent, birefringent or in any other way polarization dependent.

Safety and compliance

The product fulfills the RoHS and REACH compliance standards. The customer is solely responsible to comply with all relevant safety regulations for integration and operation.

For more information on optical, mechanical, and electrical parameters, please contact sales@optotune.com

Packaging

The EL-7-20 is available in single units packaged in a box or in trays of 20 units each.

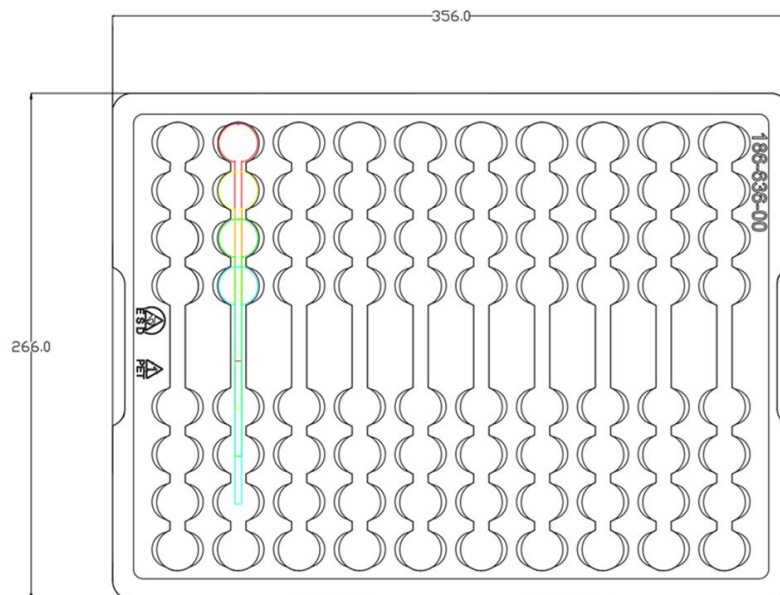

Figure 13: EL-7-20 packaging in trays.