

Reluctance force-based laser speckle reducer LSR-5

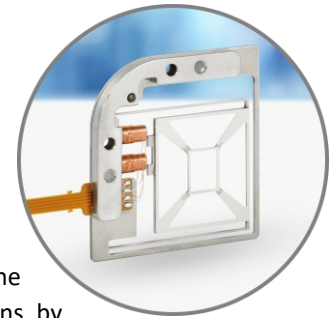

A way to reduce speckle noise from a laser-based system is by dynamically diffusing the laser beam. Optotune's LSR-5 speckle reducer averages multiple speckle patterns by dynamically displacing a diffuser, and by doing so creates a more homogeneous, speckle-free beam. The diffuser is mounted in a metallic frame and is set into motion by the reluctance force generated in the oscillating magnetic field of a driving coil. The compact driving electronics, assembled on a flexible plastic substrate, stabilizes the resonance frequency in closed-loop mode and includes an error signal.

For further details on the despeckling performance of our laser speckle reducers, please refer to our LSR [application note](#).

Mechanical specifications

Clear aperture	5 x 5	mm
External dimensions	35.2 x 37.85 x 5.5	mm
Weight	11.0	g
Mechanical clamping	2x M2 screws	

Performance specifications

Oscillation amplitude (peak to peak)	Min: 0.6 Typical: 0.8 Max: 2.0	mm
Oscillation frequency	138 ± 12	Hz
Device start-up time (typical)	20	s

Optical specifications

Material	Fused silica	
Diffusion angle (FWHM)	8.5 (other upon request)	°
Transmission wavelength	VIS coated: 440-680 Uncoated: approx. 200-2200	nm
Transmission	VIS coated: >98 Uncoated: >94	%
Depolarization	< 0.1	%
Coating	High power, double-sided	
Damage threshold	> 600	W/cm ²
Scratch/dig	60/40	Over clear aperture of diffuser

Electrical specifications

Power supply (micro-USB or solder pads) ¹	3.4-5.5	VDC
Power consumption (with std. electronics)	50	mW

¹ 100-230 VAC to 5 VDC micro-USB power supply available.

Environmental specifications

Operating temperature at fixed startup temperature T_s^2	T_s-5 to T_s+55	°C
Storage temperature	-40 to +85	°C
Start-up temperature	-30 to +85	°C
Mechanical shock	500	<i>g</i>
Cycle life	>40 000	hours

Overview of available standard products

Standard Product	Coating	Diffusion angle
LSR-5-8.5S-VIS-1D	VIS-coated	8.5°
LSR-5-8.5S-NOC-1D	uncoated	8.5°

Accessories	Description
Bracket kit LSR-4	Bracket for single and double diffusor configuration
LSR-4C-LL-mounting kit	Mounting kit for double diffusor configuration
PS-5V-US	5V DC micro-USB power supply with US plug
PS-5V-EU	5V DC micro-USB power supply with EU plug

Assemblies	Components to order
LSR-5-L (no bracket)	1x LSR-5, 1x Power supply
LSR-5-L (with bracket)	1x LSR-5, 1x Bracket-kit LSR-4, 1x Power supply
LSR-5-LL (double diffusor configuration with bracket)	2x LSR-5, 1x Bracket-kit LSR-4, 1x LSR-4C-LL-mounting kit, 2x Power supply
LSR-5-L (no bracket)	1x LSR-5, 1x Power supply

Control

The LSR-5 can be driven using a 5 V DC power supply or via USB connection to a PC. No further driver electronics are needed; the device settles into its optimal trajectory once powered on.

² Outside this temperature range, the speckle reduction efficiency may decrease. This is due to possible changes in resonance frequency, and therefore oscillation amplitude, of the device.

Mechanical layout

The mechanical layout of the LSR-5 is shown in Figure 1. To guarantee optimal performance and maximum oscillation amplitude, it is recommended to mount the LSR-5 onto a rigid mechanical holder (minimum 500 g recommended). For that purpose, two mounting holes for M2 screws are available.

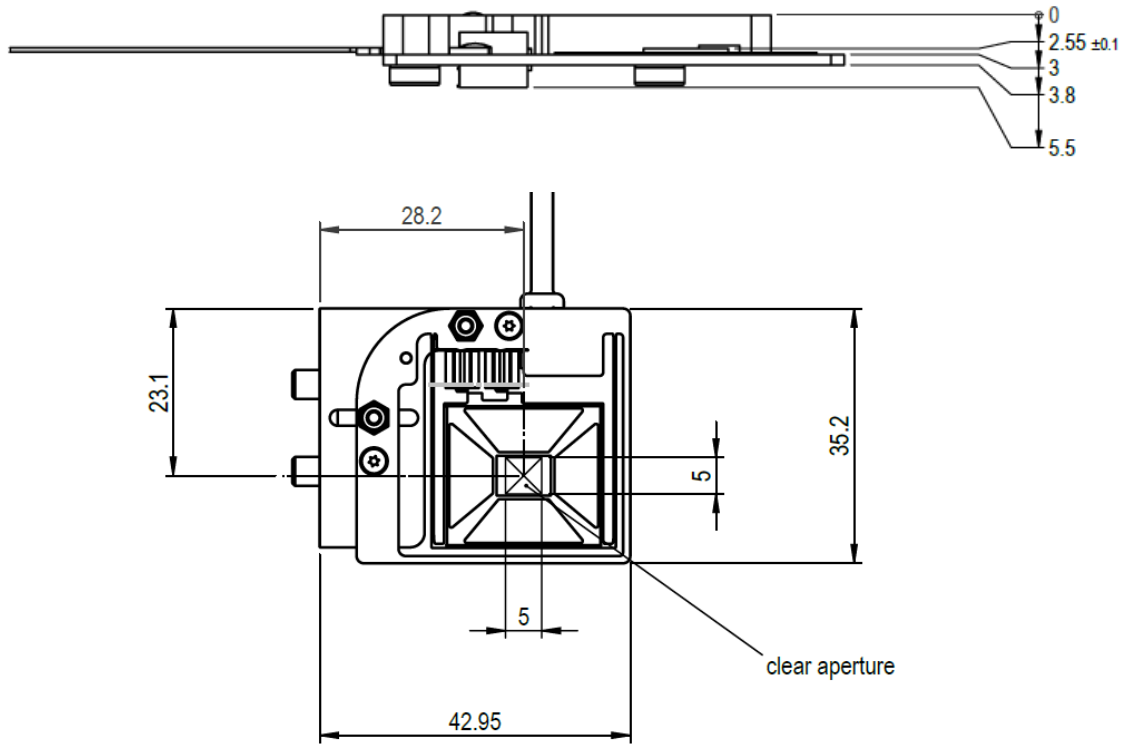

Figure 1: Mechanical drawing of the LSR-5 (unit: mm).

The flex electronics of the LSR-5 are illustrated in Figure 2.

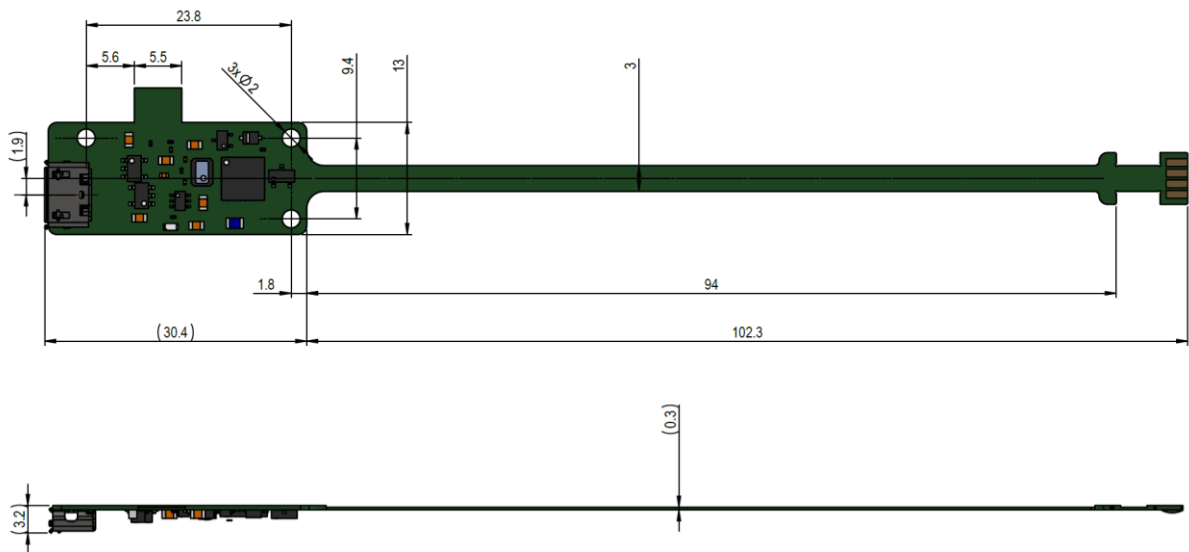

Figure 2: Mechanical drawing of the LSR-5 flex electronics (unit: mm)

Optotune additionally offers a brass mechanical holder (bracket kit, weight 43 g) that allows for mounting the LSR into an existing setup, see Figure 3. With this holder, a rigid mechanical integration is guaranteed. It further allows for mounting two crossed LSR-5 (rotated by 90°) for even higher speckle reduction. See Figure 4. For this, the LSR-4C-LL-mounting kit needs to be purchased separately.

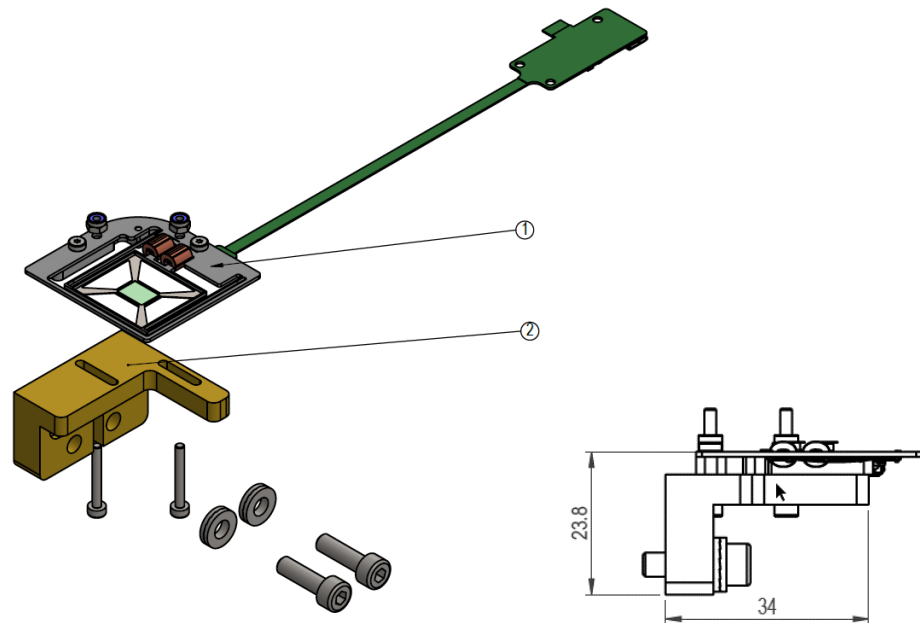

Figure 3: Mechanical layout of the LSR-5-L (with bracket) assembly. The LSR-5 (1) is mounted onto the bracket (2) which in turn can be mounted into an existing setup.

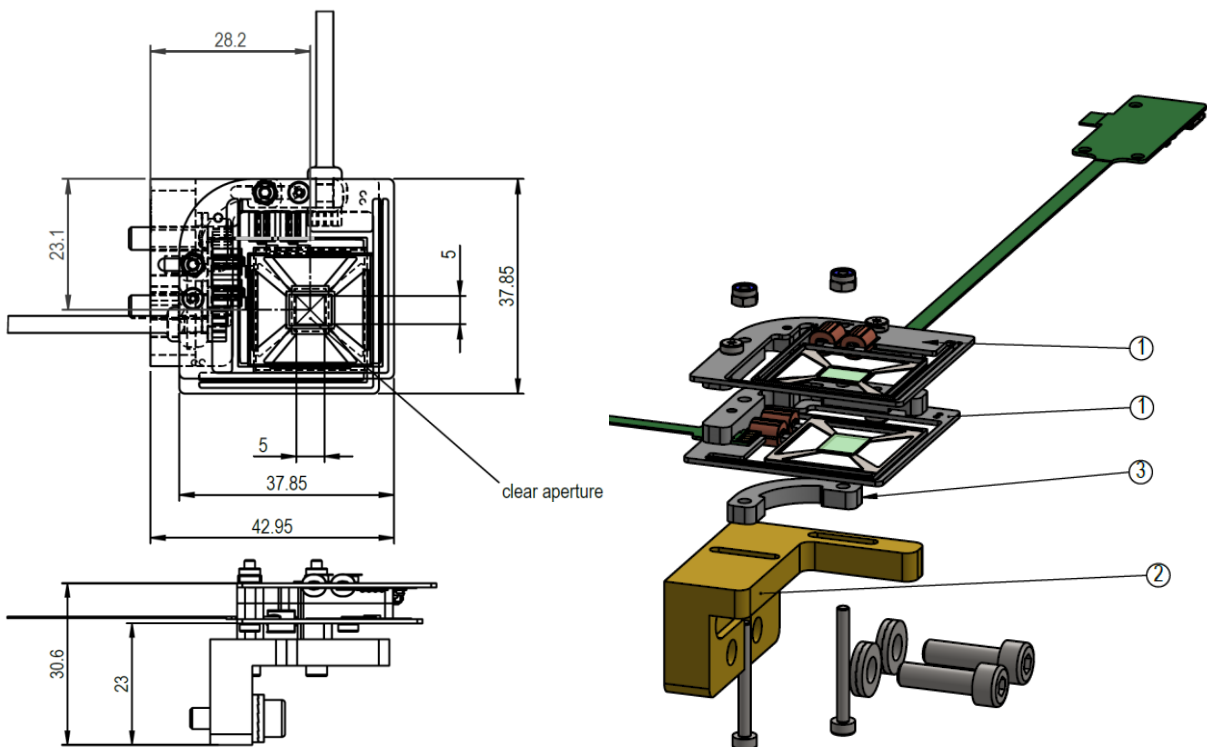

Figure 4: Mechanical layout of the LSR-5-LL (double diffusor with bracket) assembly: (1) LSR-5, (2) Bracket kit LSR-4, (3) LSR-4C-LL-mounting kit.

Custom products

Optotune offers customized versions of the LSR-5. Diffusors with different diffusion angles can be incorporated into the device and special coatings are available on request. In order not to affect the device dynamics negatively, a custom diffusor needs to have a mass within -6% to +16% of the standard diffusor. A custom diffusor should have the dimensions $(8.5 \pm 0.1 \text{ mm}) \times (6.5 \pm 0.1 \text{ mm}) \times (0.3 \pm 0.1 \text{ mm})$.

The diffusion angle of the LSR-5-8.5S-VIS-1D is defined as the full width half maximum (FWHM) of the profile of the emerging beam, see Figure 5.

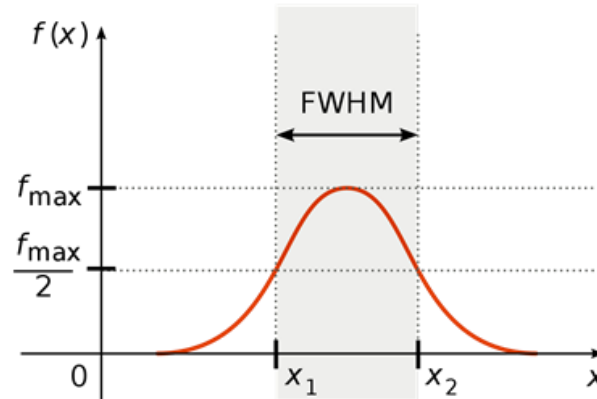

Figure 5: Definition of the diffusion angle as the FWHM of a given profile.

Electrical layout

A micro-USB connection is available on the LSR-5 to provide the needed 5 V supply voltage. Instead of using the USB connector, the LSR-5-8.5S-VIS-1D can be driven directly by a voltage source using the GND and V_{cc} (3.4 V to 5 V) soldering pad. See Figure 6.

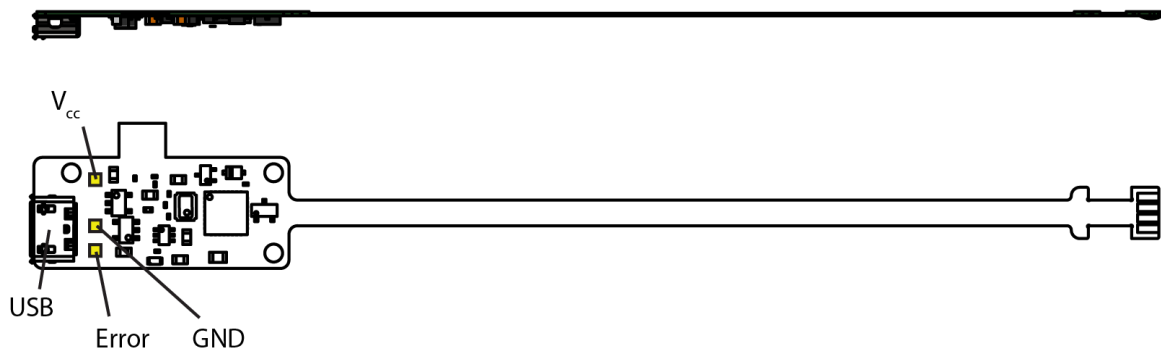

Figure 6: Electrical layout of the LSR-5-8.5S-VIS-1D.

For visual indication, there is an LED on the flex electronics that lights up when the LSR-5 is operating without errors and is turned off otherwise. The same signal is given to the Error pin. For stable operation, the signal is “low”. If e.g. the LSR-5 oscillation amplitude is outside of a certain range, the error signal switches to “high”. The error signal is realized as an open collector.

Transmission

Figure 7 shows the transmission spectrum of the LSR-5 with the coated VIS-standard diffuser. The transmission stays above 98% over the specified range of wavelengths from 440 to 660 nm. Figure 8 shows the transmission spectrum of the LSR-5 with the uncoated standard diffuser.

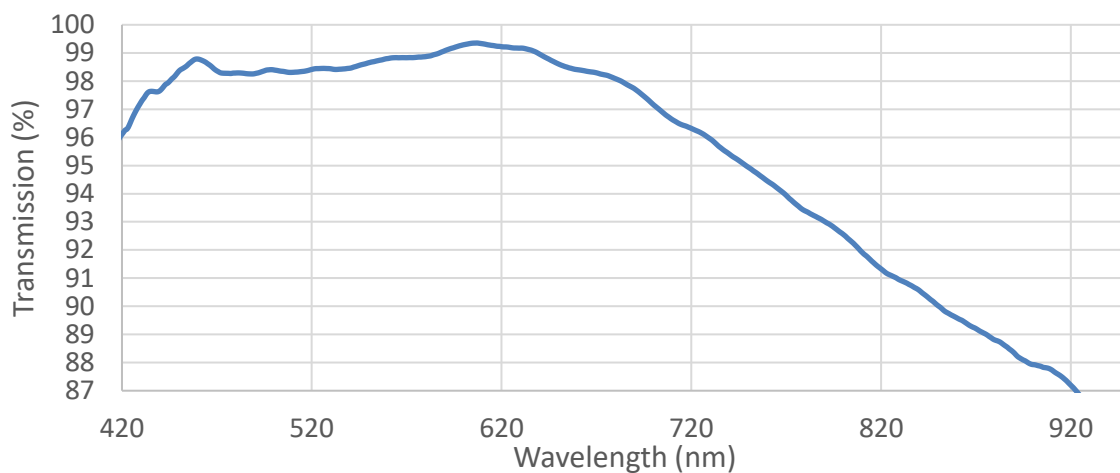

Figure 7: Transmission spectrum of the coated standard diffuser.

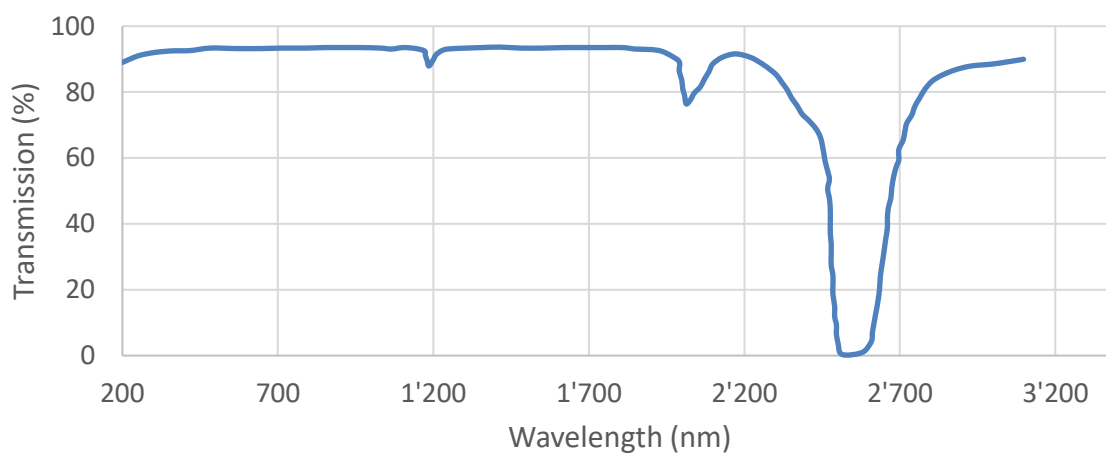

Figure 8: Transmission spectrum of the uncoated standard diffuser.

Packaging

Single LSR-5 units ship in membrane boxes. Larger volumes ship in ESD-safe and stackable PET trays of 10 LSR-5 units each, sealed in vacuum bags (Figure 9).

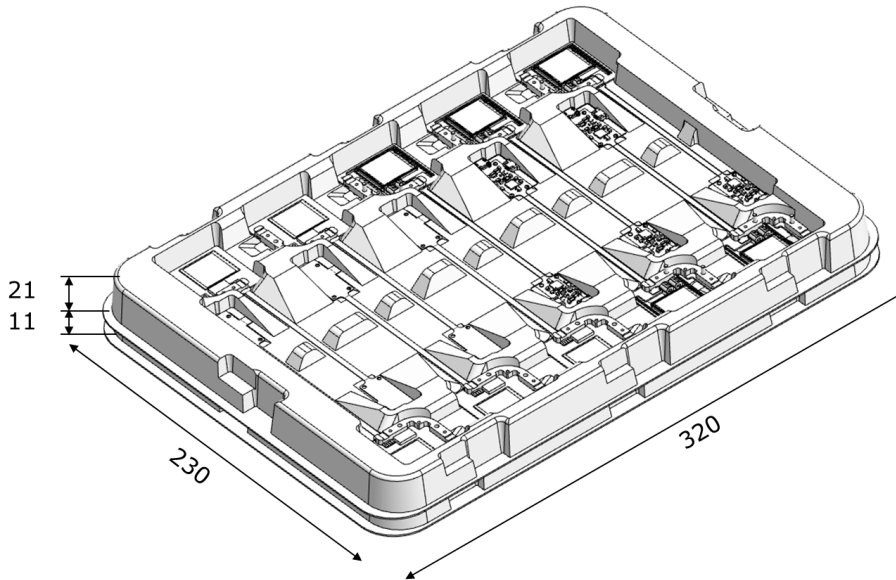

Figure 9: Shipping tray design.

Safety and compliance

The product fulfills the RoHS, REACH, CE and flammability UV94 V-0 compliance standards. The customer is solely responsible for complying with all relevant safety regulations for integration and operation, including EMC compliance.

For more information on optical, mechanical, and electrical parameters, please contact sales@optotune.com.