

ELM-S evaluation kit



Optotune’s lineup of electrically tunable lens modules (ELMs) provides optically optimized, integrated solutions that simplify the design of vision systems. As part of the entocentric ELM-F series, Optotune offers a number of S-mount ELMs designed for best performance, compactness, camera compatibility, and ease of use.

The ELM-S evaluation kit combines a board-level camera with an S-mount ELM and integrated lens controller. The kit is compatible with a wide range of Optotune’s S-mount ELMs and allows for testing the performance of Optotune’s most compact focus tunable lenses in a system without added integration efforts.

Mechanical specifications

Outer dimensions w/o drivers and cabling (WxDxH)	58 x 44.1 x 15.3	mm
Mounting	M4	
Camera cable length	1	m
Lens controller cable length	1	m

Optical specifications

	Basler daA1920	Basler daA3840	
Focal length	6, 8, 12, 16, or 25		mm
f/#	f/3.4, f/3.5, f/5.6		
Working distance range	50 to infinity 150 to infinity		mm
Camera resolution	1920 × 1200	3840 × 2160	px
Pixel size	3.45 × 3.45	2.0 × 2.0	µm
Sensor format	1/2.3	1/1.8	“
Sensor size	6.6 × 4.2	7.68 × 4.32	mm
Shutter type	global	rolling	

Lens specifications

	EL-3-10	EL-3.1-10.8	
Clear aperture	3	3.1	mm
Focal power range (20°C)	-13 to +13	-10 to +10	dpt
Transmission range, 95% transmittance		420 to 900	nm
Response time (80% of step)	<1	1	ms
Settling time (80% of step)	2 / 4	3 / 7	ms (low-pass filtered / normal step signal)
Lifecycles (10% - 90% sinusoidal)		> 1'000'000'000	cycles
Operating temperature	-20 to +65°C	-20 to +85°C	°C
Storage temperature	-50 to +85°C	-40 to +85°C	°C

Electrical specifications and interfaces

Nominal control current	-120 to +120	-100 to +100	mA
Motor coil resistance (25-30°C)	7.1	8.0	Ω

Lens power consumption (full tuning range)	0 - 0.1	0 - 0.05	W
Lens controller power consumption (max)		1.5	W
Camera power consumption		0.6 – 2	W
Camera interface	USB 3.0		
Lens controller (ECC-1C) interface	USB 3.0		

Overview of available components

S-mount ELM

(coming soon) ELM-6-3.5-9-S, ELM-6-5.6-9-S

(coming soon) ELM-8-3.4-9-S, ELM-8-5.6-9-S

ELM-12-5.6-9-S

(coming soon) ELM-12-3.4-9-S, ELM-12-5.6-9-S

ELM-16-5.6-9-S

ELM-25-5.6-9-S

(coming soon) ELM-25-5.1-9-S

Optotune lens inside

EL-3.1-10.8

EL-3.1-10.8

EL-3-10

EL-3.1-10.8

EL-3-10

EL-3-10

EL-3.1-10.8

Board-level camera

Description

Specifications

Basler daA1920-160uc	High frame rate, color	2.3MP, global shutter 160fps, USB3 Vision
Basler daA1920-160um	High frame rate, monochromatic	2.3MP, global shutter 160fps, USB3 Vision
Basler daA3840-45uc	High resolution, color	8.3MP, rolling shutter 45fps, USB3 Vision
Basler daA3840-45um	High resolution, monochromatic	8.3MP, rolling shutter 45fps, USB3 Vision

Mechanical layout

Figure 1 shows the mechanical layout of the ELM-S development kit, consisting of a selected board-level camera, ELM-S model, and controller adapter. For more details on the mechanics of the individual components, please refer to the corresponding [datasheets](#).

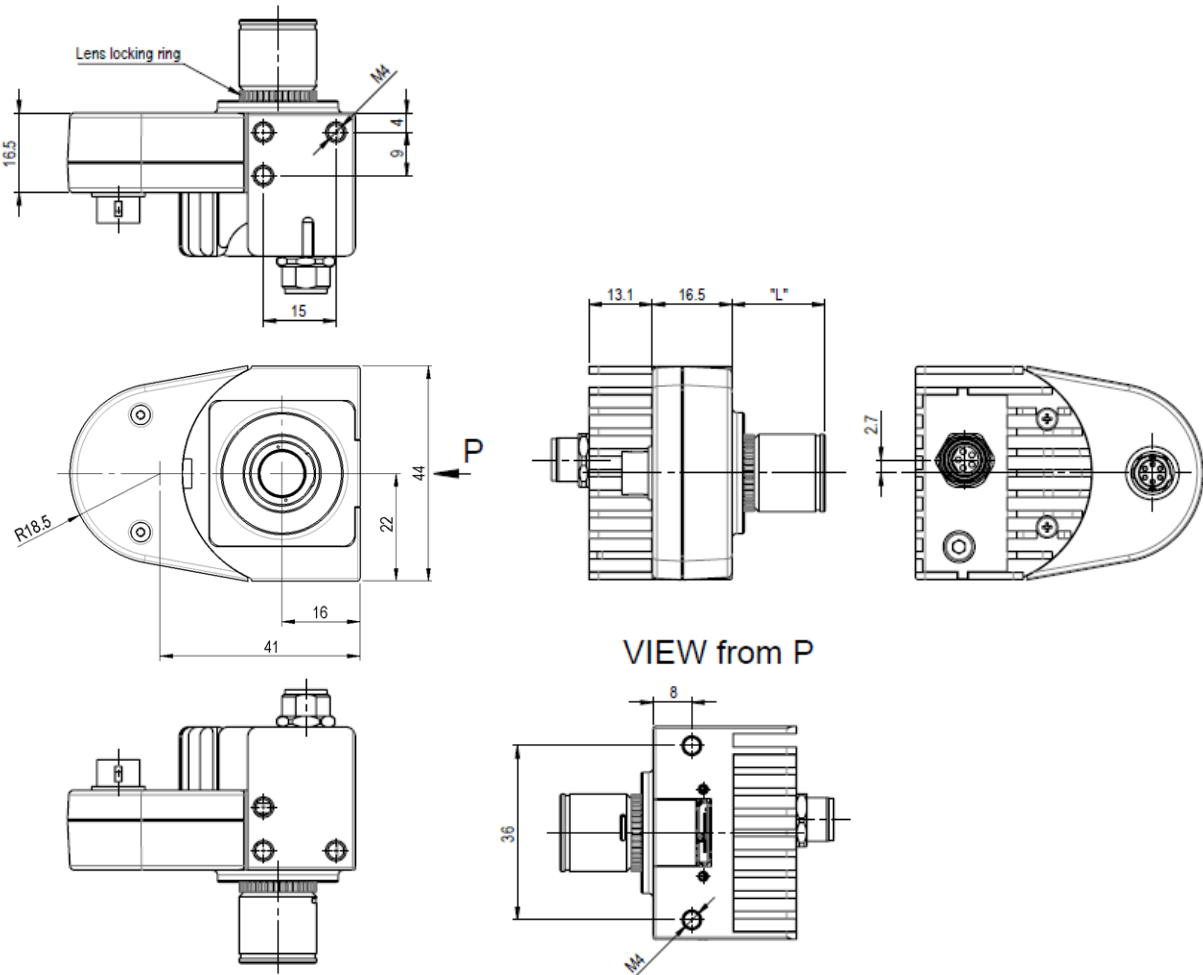
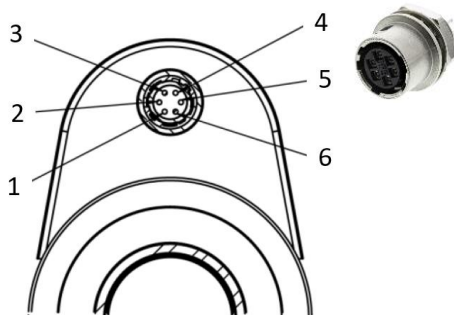

Figure 1: Mechanical drawing of the ELM-S development kit (unit: mm).

Electrical connection

The ELM-S development kit is offered with the embedded current controller ECC-1C. The connection is realized using a Hirose UART-to-USB cable directly to a computer.



Pin out Hirose connector HR10G-7R-6SB(73)		
Position	Function	Value
1	GPIO Trigger	3V3 logic
2	Analog In	0-10V
3	UART Tx / I ² C SCL	3V3 logic
4	UART Rx / I ² C SDA	3V3 logic
5	GND	-
6	VCC input	5V / 9-24V

Figure 2: Electrical connections of ECC-1C featuring (female) Hirose connector.

For triggering or UART/I²C operation, the Hirose-to-open-ended wire cable (CAB-6-100-M-OE, sold separately) is required.

Focus tunable lens characteristics

For more information on focal power versus current, transmission, wavefront quality, temperature effects, response time, frequency response, and transmission of the EL-3.1-10.8 and EL-3-10, please refer to the respective datasheets, available on the Optotune [downloads](#) page.

For operating instructions and additional support, please contact sales@optotune.com.